

# ***Integrated Amplifier/Video Cassette Recorder***

---

Operating Instructions

**VHS**

**Hi-Fi**

**VCR** *Plus+*

**SLV-AV100U/C**

# WARNING

To prevent fire or shock hazard, do not expose the unit to rain or moisture.

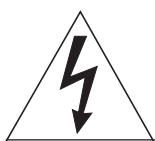
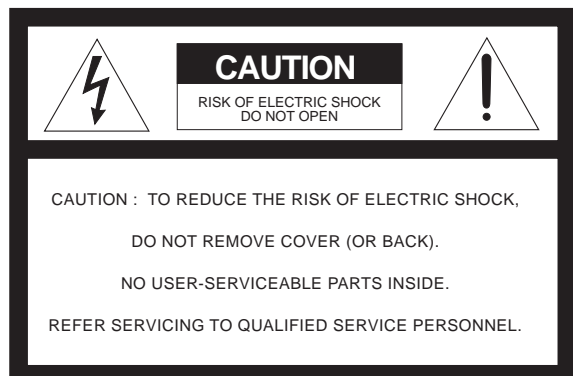

This symbol is intended to alert the user to the presence of uninsulated “dangerous voltage” within the product’s enclosure that may be of sufficient magnitude to constitute a risk of electric shock to persons.



This symbol is intended to alert the user to the presence of important operating and maintenance (servicing) instructions in the literature accompanying the appliance.

## CAUTION

To prevent electric shock, do not use this polarized AC plug with an extension cord, receptacle or other outlet unless the blades can be fully inserted to prevent blade exposure.

## Precautions

### Safety

- Operate the unit only on 120 V AC, 60 Hz.
- If anything falls into the cabinet, unplug the unit and have it checked by qualified personnel before operating it any further.
- One blade of the plug is wider than the other for the purpose of safety and will fit into the power outlet only one way. If you are unable to insert the plug fully into the outlet, contact your Sony dealer.
- Unplug the unit from the wall outlet if you do not intend to use it for an extended period of time. To disconnect the cord, pull it out by the plug, never by the cord.

### Installing

- Allow adequate air circulation to prevent internal heat buildup.
- Do not place the unit on surfaces (rugs, blankets, etc.) or near materials (curtains, draperies) that may block the ventilation slots.
- Do not install the appliance in a confined space, such as a bookcase or built-in cabinet.
- Do not install the unit near heat sources such as radiators or air ducts, or in a place subject to direct sunlight, excessive dust, mechanical vibration or shock.

- Do not install the unit in an inclined position. It is designed to be operated in a horizontal position only.
- Keep the unit and cassettes away from equipment with strong magnets, such as microwave ovens or large loudspeakers.
- Do not place heavy objects on the unit.
- If the unit is brought directly from a cold to a warm location, moisture may condense inside the VCR and cause damage to the video head and tape. When you first install the unit, or when you move it from a cold to a warm location, wait for about one hour before operating the unit.

## Information

### For customers in the USA

This equipment has been tested and found to comply with the limits for a Class B digital device, pursuant to Part 15 of the FCC Rules. These limits are designed to provide reasonable protection against harmful interference in a residential installation. This equipment generates, uses, and can radiate radio frequency energy and, if not installed and used in accordance with the instructions, may cause harmful interference to radio communications. However, there is no guarantee that interference will not occur in a particular installation. If this equipment does cause harmful interference to radio or television reception, which can be determined by turning the equipment off and on, the user is encouraged to try to correct the interference by one or more of the following measures:

- Reorient or relocate the receiving antenna.
- Increase the separation between the equipment and receiver.
- Connect the equipment into an outlet on a circuit different from that to which the receiver is connected.
- Consult the dealer or an experienced radio/TV technician for help.

You are cautioned that any changes or modifications not expressly approved in this manual could void your authority to operate this equipment.

### Caution

Television programs, films, video tapes and other materials may be copyrighted. Unauthorized recording of such material may be contrary to the provisions of the copyright laws. Also, use of this recorder with cable television transmission may require authorization from the cable television transmission and/or program owner.

## Owner’s record

The model number is located at the rear and front of the unit and the serial number on the top. Record these numbers in the spaces provided below. Refer to them whenever you call upon your Sony dealer regarding this product.

Model No. \_\_\_\_\_

Serial No. \_\_\_\_\_

# Table of contents

## Getting Started

- 4 Step 1: Unpacking
- 5 Step 2: Setting up the remote commander
- 6 Step 3: Speaker systems hookup
- 8 Step 4: Various audio/video hookups
- 11 Step 5: TV antenna or cable hookups
- 30 Adjusting the SOUND SET with EASY SET UP
- 33 Setting the clock
- 35 Setting up cable box control
- 39 Presetting channels
- 43 Setting up VCR Plus+ \*1
- 45 Presetting radio stations

## Basic VCR / Radio Operations

- 47 Playing a video tape
- 49 Using the pre-programed sound fields
- 50 Recording TV programs
- 51 Recording TV programs using VCR Plus+
- 54 Setting the timer manually
- 56 Checking/changing/cancelling timer settings
- 58 Listening to the radio

## Audio/Video Equipment Operations

- 59 Selecting the equipment
- 62 Controlling VCRs
- 64 Controlling the TV
- 66 Playing back a CD
- 67 Controlling a cassette deck
- 69 Controlling a DAT deck
- 71 Controlling an MD deck
- 73 Controlling an LD player

## Sound Field Operations

- 75 Taking advantage of the sound fields
- 77 Getting the most out of Dolby Pro Logic Surround\*2 sound
- 78 Customizing the sound fields
- 82 Reconfiguring the PROLOGIC and THEATER sound fields

## Advanced VCR Operations

- 84 Playing/searching at various speeds
- 85 Recording TV programs using the quick timer
- 86 Recording stereo and bilingual programs
- 87 Searching using the index function
- 88 Adjusting the picture
- 89 Changing menu options

## Editing

- 90 Recording from another VCR or LD player

## Additional Information

- 91 Customizing the remote commander function buttons
- 92 General setup information
- 94 Troubleshooting
- 97 Specifications
- 98 Index to parts and controls
- 103 Index

- Back Cover** Quick reference to using the VCR

\*1 VCR Plus+ and PlusCode are trademarks of Gemstar Development Corporation. VCR Plus+ system is manufactured under license from Gemstar Development Corporation.

\*2 This unit uses the Dolby Surround system, manufactured under license from Dolby Laboratories Licensing Corporation. DOLBY, the double-D symbol , and PRO LOGIC are trademarks of Dolby Laboratories Licensing Corporation.

# Step 1

## Unpacking

Check that you have received the following items with the unit:

- Remote commander

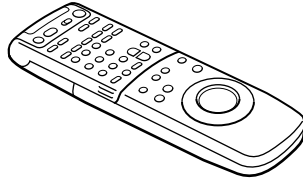

- AM loop antenna

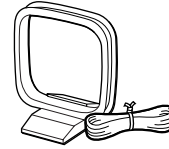

- Size AA (R6) batteries

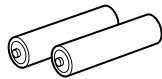

- FM wire antenna

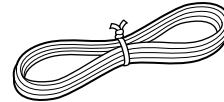

- 75-ohm coaxial cable with F-type connectors

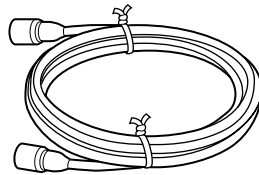

- Video cable (1 phono to 1 phono)

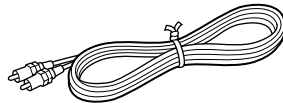

## Step 2

# Setting up the remote commander

### Inserting the batteries

Insert two size AA (R6) batteries matching the + and – on the batteries to the diagram inside the battery compartment.

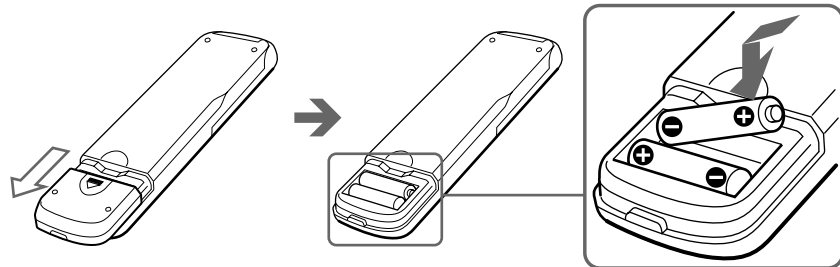

### Using the remote commander

You can use this remote commander to operate this unit, a TV, other VCRs, an LD deck, CD player, cassette deck, DAT deck, and MD deck (all equipment must be made by Sony). For details on how to operate other equipment with this remote commander, see "Audio/Video Equipment Operations" from page 59.

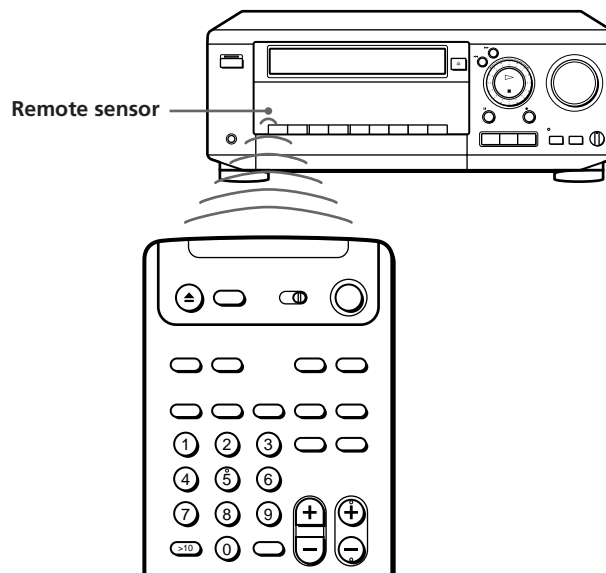

### Notes

- The remote commander is initially set to control this unit. However, if it doesn't control the unit, press VHS TUNER first. If the remote commander still doesn't operate, read "Controlling VCRs" on page 62 first.
- With normal use, the batteries should last about three to six months.
- If you do not use the remote commander for an extended period of time, remove the batteries to avoid possible damage from battery leakage.
- Do not use a new battery with an old one.
- Do not use different types of batteries.

# Step 3

## Speaker systems hookup

To get the best possible sound from the unit, connect front (left and right), center, and rear (left and right) speakers. You need to connect either the center or rear speakers as well as the front speakers to enjoy Dolby Pro Logic Surround sound.

### Before you connect...

- Prepare speaker cords (one for each speaker) (not supplied).



- Be sure to match the speaker cords to the appropriate terminals on the components: + to +, and - to -. (If the cords are reversed, the sound will be distorted and the bass sound will not be reproduced well.)
- Do not connect the AC power cord until you finish all the connections through “Step 5 : TV antenna or cable hookups” on page 11.
- Be sure to make connections firmly to avoid hum and noise.

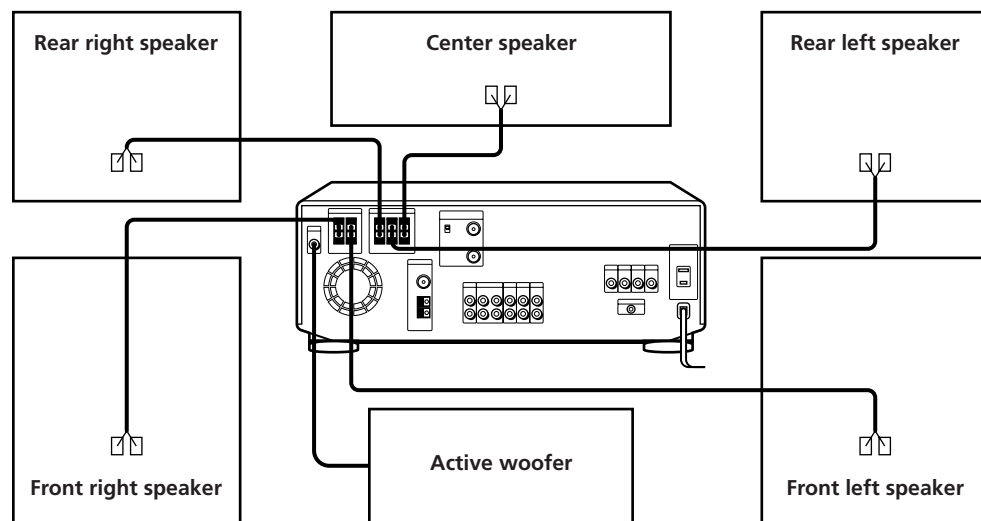

# 1

### Connect the front speakers to the FRONT SPEAKERS L/R connectors.

Twist about 15 mm of the stripped ends of the cord. Then insert the stripped ends into the connectors as shown on the right.

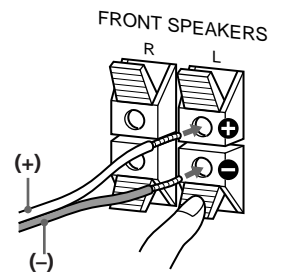

# 2

### Connect the center speaker to the SURROUND SPEAKERS CENTER connectors.

Repeat step 1 above for the center speaker. If you don't have a center speaker, skip this step.

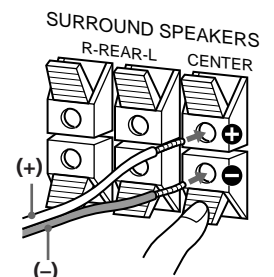

# 3

## Connect the rear speakers to the SURROUND SPEAKERS REAR L/R connectors.

Repeat step 1 above for the surround speakers. If you don't have rear speakers, skip this step.

### Note

- Be sure to connect both left and right speakers. If you connect only one speaker, the rear speaker won't reproduce the sound.

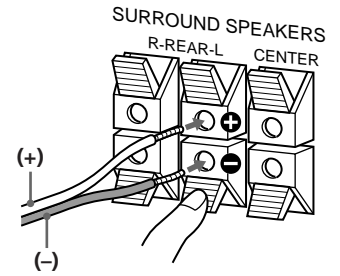

## Placing the speakers

For optimum surround sound effect, place your speakers as shown below.

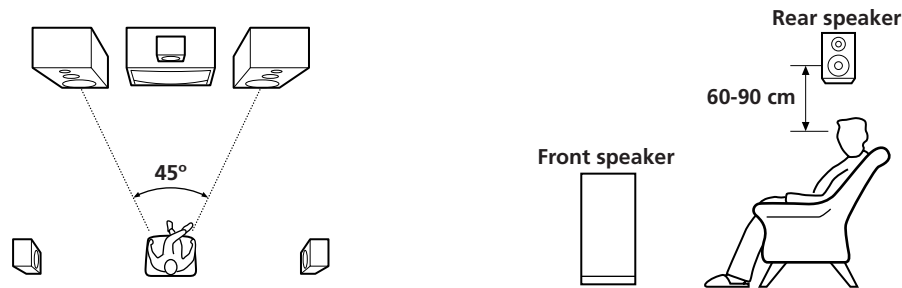

### Tips

- Position the center speaker so the face of the speaker is aligned evenly with, or slightly behind the faces of the front left and right speakers.
- Mount the surround (rear) left and right speakers on the walls so they face each other.
- Position the front left and right speakers and center speaker as close to the same height as possible.

## Connecting an active woofer

For further sound improvement, connect an active woofer to MIX OUT with an audio cable (not supplied). The active woofer will increase bass response. The position of the active woofer does not affect the sound quality very much.

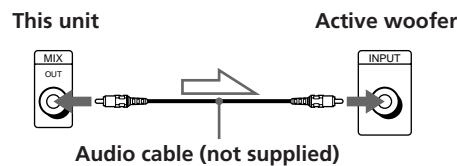

## Listening through the headphones

Connect the headphones to PHONES. No sound will be reproduced from the speakers.

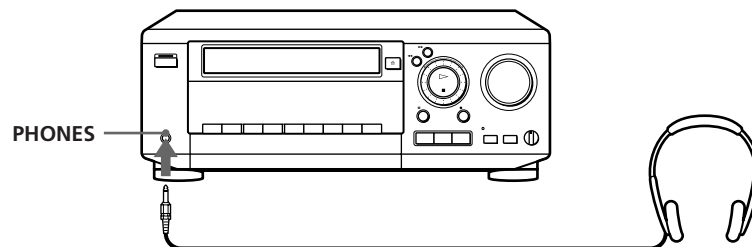

# Step 4

## Various audio/video hookups

The following connections with various audio/video equipment are recommended examples. The actual connections may vary depending on the equipment you have.

### Before you connect....

- Prepare audio (not supplied) and video cables referring to the following table.

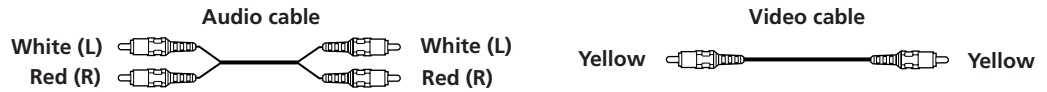

Equipment	Necessary cable for each piece of equipment
Tuner/CD player	One audio cable
MD deck/DAT deck/cassette deck	Two audio cables
Satellite tuner/LD player/other VCR	One video cable and one audio cable
TV	One video cable and one audio cable
Monitor	One video cable

- Turn off the power to all equipment before making any connections.
- Do not connect the AC power cord until all of the connections are complete.
- Be sure to make connections firmly to avoid hum and noise.

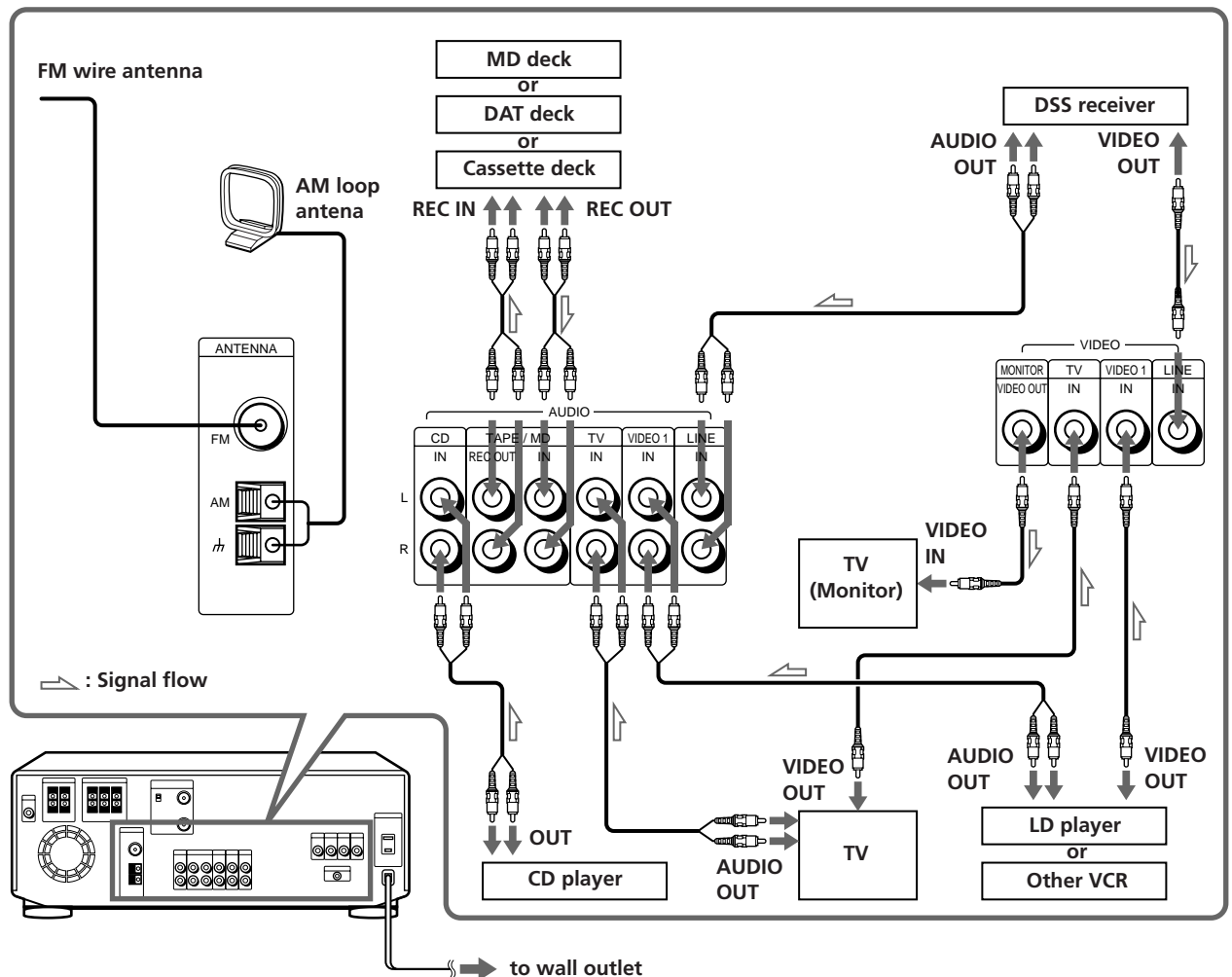



**1**

**Connect your audio/video equipment using audio and video cables (not supplied) referring to the illustration on page 8.**

Make sure you connect the audio and video cable plugs to jacks of the same color.

**2**

**Connect the AC power cord to the wall outlet.**

## Connecting to the front VIDEO 2 INPUT jacks

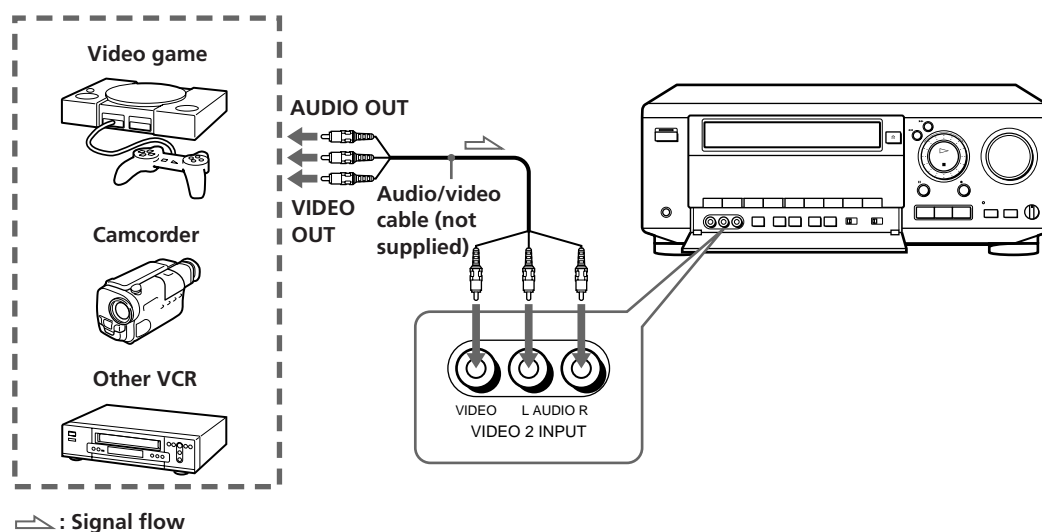

### Notes

- Make sure you connect the audio/video plugs to jacks of the same color.
- If the other VCR is a monaural type, connect only the VIDEO and AUDIO L jacks.

## Connecting to the AC OUTLET

You can connect an audio component (or components through an optional multi-outlet extension cord) to AC OUTLET on the rear of the unit. The power is supplied to AC OUTLET while the unit is turned on. The power supply stops when you turn off the unit. Using this function, you can turn on and turn off all the audio components connected to AC OUTLET at the same time if you leave those components' power switches on.

### Cautions

- Make sure you comply with the laws and regulations in your country for this connection.
- Make sure that the power consumption of the components connected to AC OUTLET doesn't exceed 120 watts. Do not connect high-wattage electrical home appliances such as electric irons, fans, or TVs to this outlet.

### Notes

- The power will not be supplied to the components as long as the unit is turned off. Any electronic memory of the components may be cleared if you make this connection.
- Some audio components may not turn on with this connection.

### Connecting FM/AM antennas

To receive radio broadcasts with this unit, connect the FM/AM antennas (supplied).

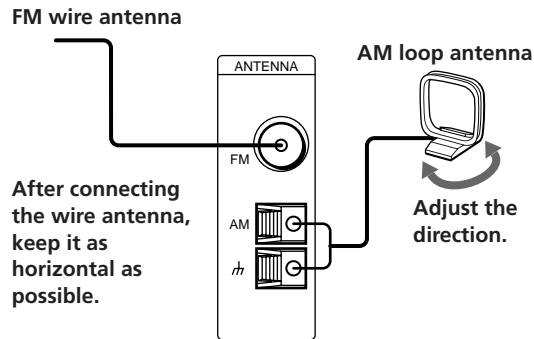

#### If AM reception is poor

We recommend that you purchase and connect the optional Sony antenna to the unit if reception is weakened by ferroconcrete used in the construction of your apartment or building.

#### If you have poor FM reception

Connect a 75-ohm coaxial cable (not supplied) to an FM outdoor antenna.

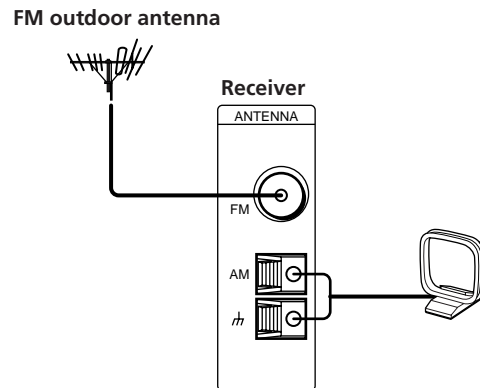

#### Note

- To prevent noise pick-up, keep the AM loop antenna away from the unit and TV. When the noise is not cleared yet, turn off the TV.

# Step 5 TV antenna or cable hookups

## Selecting the best hookup option

There are many ways in which your VCR can be hooked up. To hook up your VCR so that it works best for you, first scan through the table below. Then use the accompanying diagrams and procedures on the following pages to set up your VCR.

If you have	Use	Refer to
TV that has video input	<b>Video (V) hookup</b> , then follow one of the hookups below.	<b>Page 12</b>
Cable box that is compatible with the VCR's cable box control feature	<b>Hookup 1</b>	<b>Pages 13 to 15</b>
No cable box or incompatible cable box with only a few scrambled channels	<b>Hookup 2</b>	<b>Pages 16 to 18</b>
Antenna only, no cable TV	<b>Hookup 3</b>	<b>Pages 19 to 21</b>
Incompatible cable box with many scrambled channels	<b>Hookup 4</b>	<b>Pages 22 to 24</b>
DSS <sup>®</sup> * receiver	<b>Hookup 5</b>	<b>Pages 25 to 26</b>
Incompatible cable box with only a few scrambled channels, using an A/B switch	<b>Hookup 6</b>	<b>Pages 27 to 29</b>

After you've completed the connections, follow the instructions for setup. During setup, if you need more details on the procedure described, page numbers are provided where you can find complete, step-by-step instructions.

After you've completed the setup, you're ready to use your unit's VCR. Procedures differ depending on the hookup you used. For an overview, refer to "Quick reference to using the VCR" on the back cover.

### Before you get started

- Turn off the power to all equipment.
- Do not connect the AC power cords until all of the connections are completed.
- Be sure you make connections firmly. Loose connections may cause picture distortion.
- If your TV doesn't match any of the examples provided, see your nearest Sony dealer or qualified technician.

\* DSS<sup>®</sup> is a registered trademark of DIRECTV, Inc., a unit of Hughes Electronics Corporation.

---

## Step 5 TV antenna or cable hookups (continued)

### Video (V) hookup

You will get a better picture by connecting your TV (monitor) to MONITOR VIDEO OUT jack as the illustration shown on page 8.

### If you're no planning to use your unit's VCR to record programs

You're finished setting up the unit's VCR after you've made the connections shown on page 8.

### If you want to record off-air or off your cable TV system

Complete these connections first, and then go to the following pages for antenna or cable hookups.

### Caution

Connections between the VCR's VHF/UHF connector and the antenna terminals of the TV receiver should be made only as shown in the following instructions. Failure to do so may result in operation that violates the regulations of the Federal Communications Commission regarding the use and operation of RF devices. Never connect the output of the VCR to an antenna or make simultaneous (parallel) antenna and VCR connections at the antenna terminals or your receiver.

### Notes to CATV system installer

This reminder is provided to call the CATV system installer's attention to Article 820-40 of the NEC that provides guidelines for proper grounding and, in particular, specifies that the cable ground shall be connected to the grounding system of the building, as close to the point of cable entry as practical.

## Hookup 1

### Using cable box control

A Cable Mouse is available as an optional accessory for this model. You can order directly from Sony by calling **1-800-488-7669** and asking for Cable Mouse

**RM-CM101.**

\$14.95 + \$3.00

(shipping, handling and applicable sales tax)

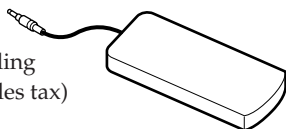

#### Recommended use

You should use this hookup if you have a cable box, especially if your cable system scrambles all or most channels. This hookup allows the VCR's cable box control feature to control the channel on the cable box, simplifying the recording process. A list of compatible cable boxes is on page 36.

#### What you can do with this hookup

- Record any channel using the VCR's cable box control feature to select channels on the cable box

#### What you can't do

- Record with the cable box turned off
- Record one channel while watching another channel

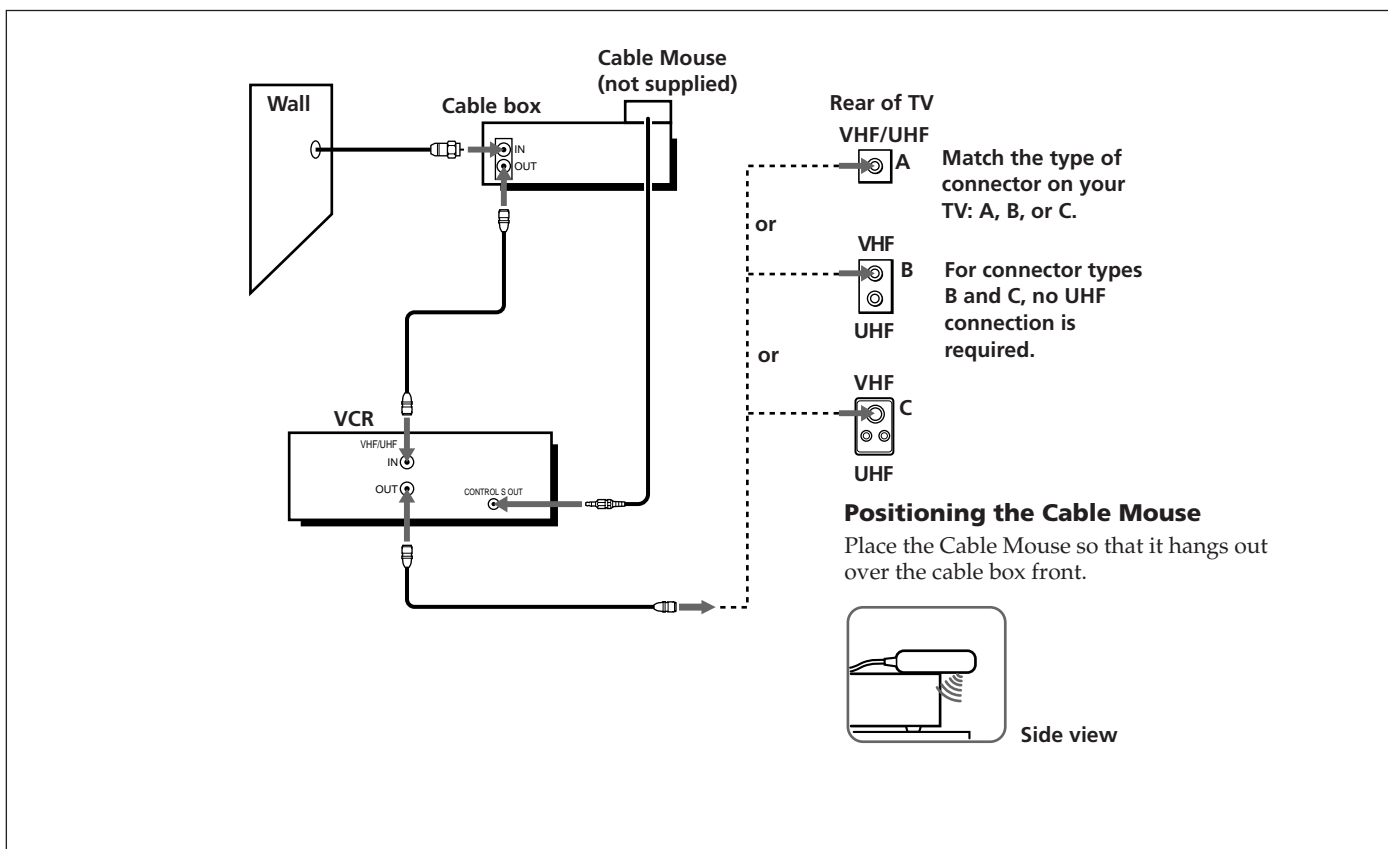

## Step 5 TV antenna or cable hookups (continued)

### Hookup 1: VCR setup

**1** Set the RF UNIT switch to CH 3 or CH 4, whichever channel is not used in your area. If both are used, set the switch to either channel.

For details, see page 92.

If you made V connections (from page 12), you can skip this step.

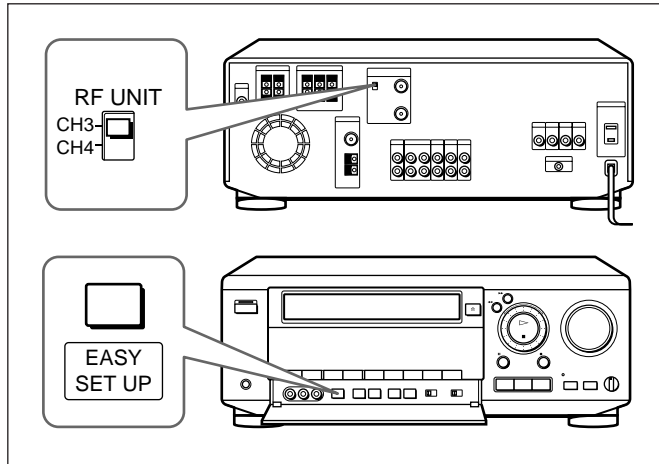

**2** Turn on your cable box.

**3** Press EASY SET UP on the VCR.

**1** The CLOCK SET menu appears. Set the date and time and press EXECUTE. For details, see page 33.

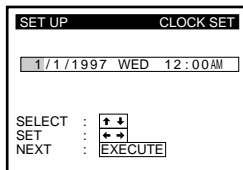

**2** The CABLE BOX CONTROL menu appears. Select ON. For details, see page 35.

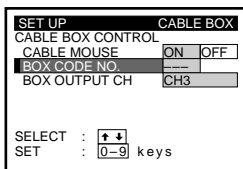

**3** Enter your cable box code number and press CURSOR↓.

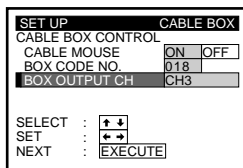

**4** Select your cable box output channel and press EXECUTE.

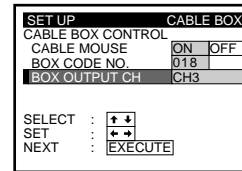

**5** The CENTER MODE selection menu appears. Select the center mode and press EXECUTE. For details, see page 30.

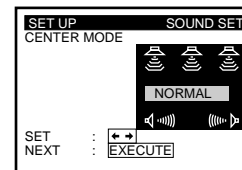

**6** The TEST TONE selection menu appears. Set the volume of the center and rear speakers and press EXECUTE. For details, see page 31.

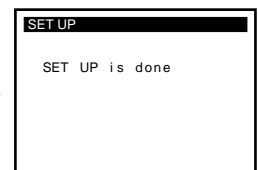
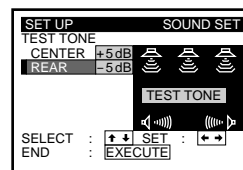
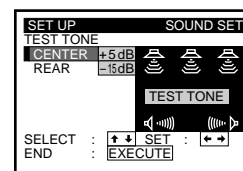

Normal display

## Hookup 1: VCR Plus+ channel setup

- 1 Find the VCR Plus+ Channel Listing in your program guide. For details, see page 43.
- 2 If the channels in the program guide are different from the channels that you actually use on your TV, set the channels that are different as follows. For details, see page 44.

- 1 Press MENU and select VHS MENU.

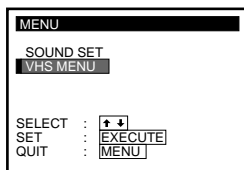

- 2 Select SET VCR Plus+ CHANNELS.

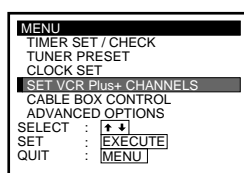

- 3 Enter the program guide channel, then the channel you use on your TV.

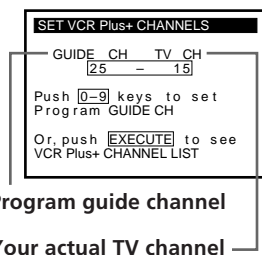

- 4 Press EXECUTE.

## Hookup 2

### No cable box, or incompatible cable box with only a few scrambled channels

#### Recommended use

Use this hookup if you do not have a cable box. Also use this hookup if your cable company cannot supply a cable box that is compatible with the VCR's cable box control feature, and your cable system scrambles only a few channels.

#### What you can do with this hookup

- Record any unscrambled channel by selecting the channel on the VCR

#### What you can't do

- Record scrambled channels that require a cable box

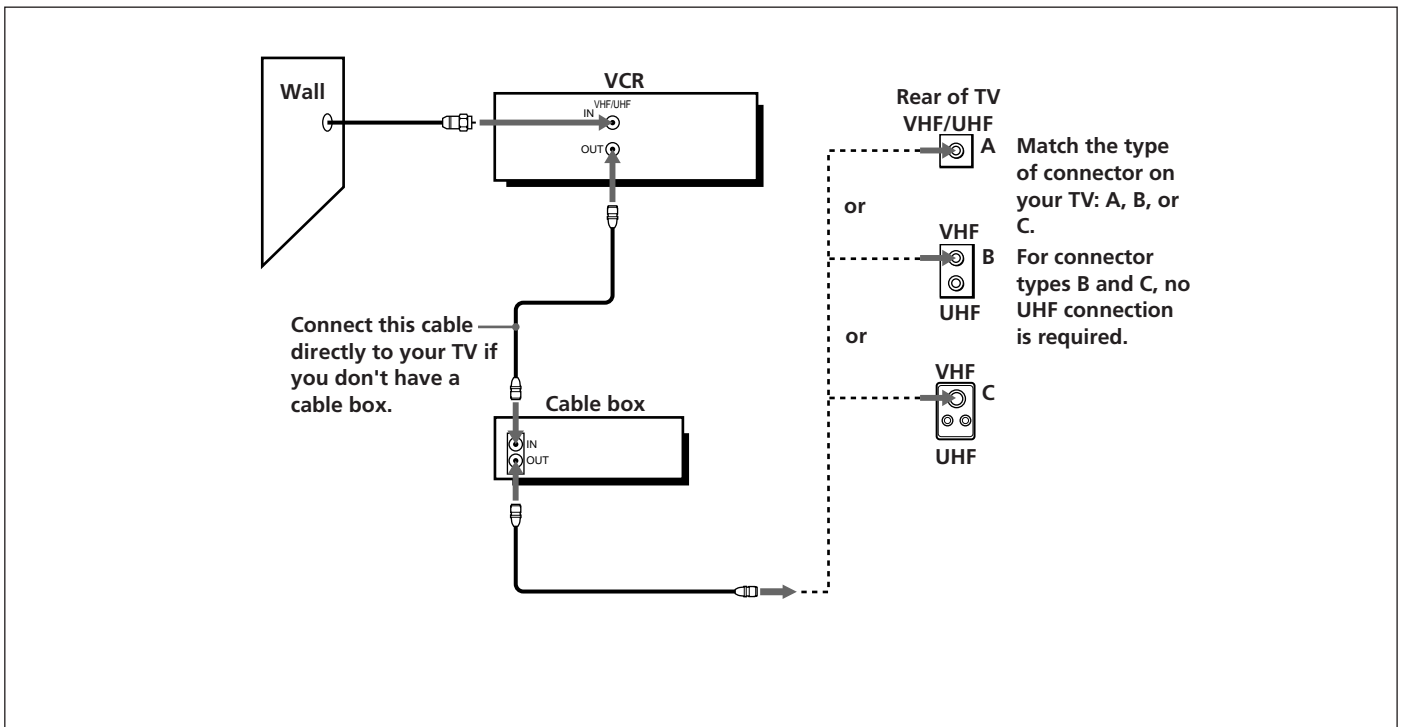



## Hookup 2: VCR setup

- 1 Set the RF UNIT switch to CH 3 or CH 4, whichever channel is not used in your area. If both are used, set the switch to either channel. For details, see page 92. If you made V connections (from page 12), you can skip this step.

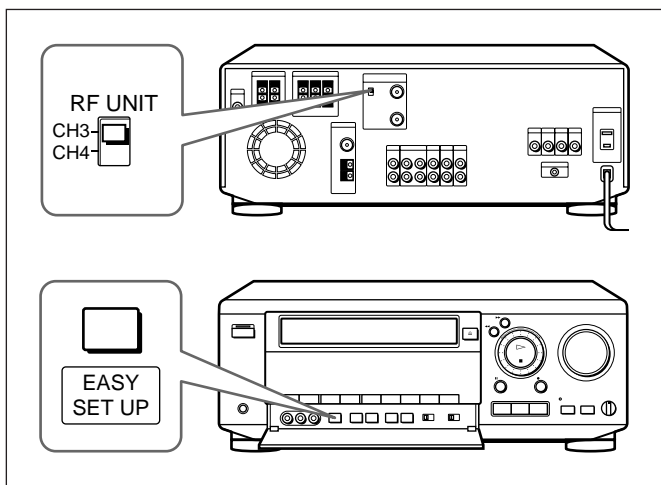

- 2 Press EASY SET UP on the VCR.

- 1 The CLOCK SET menu appears. Set the date and time and press EXECUTE. For details, see page 33.

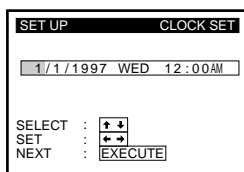

- 2 The CABLE BOX CONTROL menu appears. Select OFF and press EXECUTE. For details, see page 35.

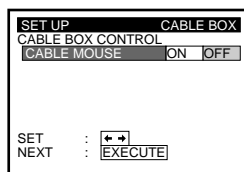

- 3 The TUNER PRESET menu appears. Set ANTENNA/CABLE to CABLE and press EXECUTE. For details, see page 39.

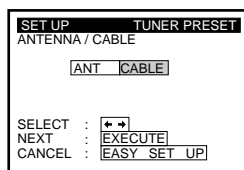

- 4 The AUTO PRESET starts.

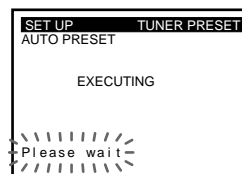

- 5 After completing AUTO PRESET, the CENTER MODE selection menu appears. Select the center mode, and press EXECUTE. For details, see page 30.

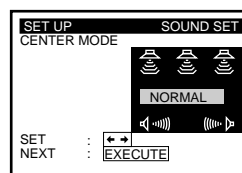

- 6 The TEST TONE selection menu appears. Set the volume of the center and rear speakers and press EXECUTE. For details, see page 31.

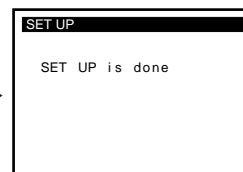
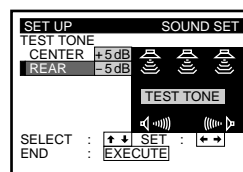
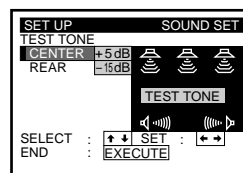

Normal display

## Step 5 TV antenna or cable hookups (continued)

### Hookup 2: VCR Plus+ channel setup

- 1 Find the VCR Plus+ Channel Listing in your program guide. For details, see page 43.
- 2 If the channels in the program guide are different from the channels that you actually use on your TV, set the channels that are different as follows. For details, see page 44.

- 1 Press MENU and select VHS MENU.

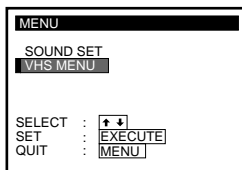

- 2 Select SET VCR Plus+ CHANNELS.

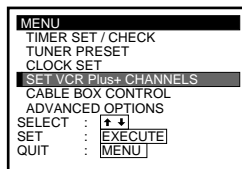

- 3 Enter the program guide channel, then the channel you use on your TV.

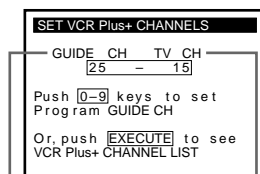

Program guide channel

Your actual TV channel

- 4 Press EXECUTE.

## Hookup 3

Make the following connections if you're using an antenna (if you don't have cable TV).

### Antenna hookup

#### A Use this hookup if you're using:

- VHF/UHF antenna (you get channels 2–13 and channels 14 and higher)
- UHF-only antenna (you get channels 14 and higher)
- Separate VHF and UHF antennas

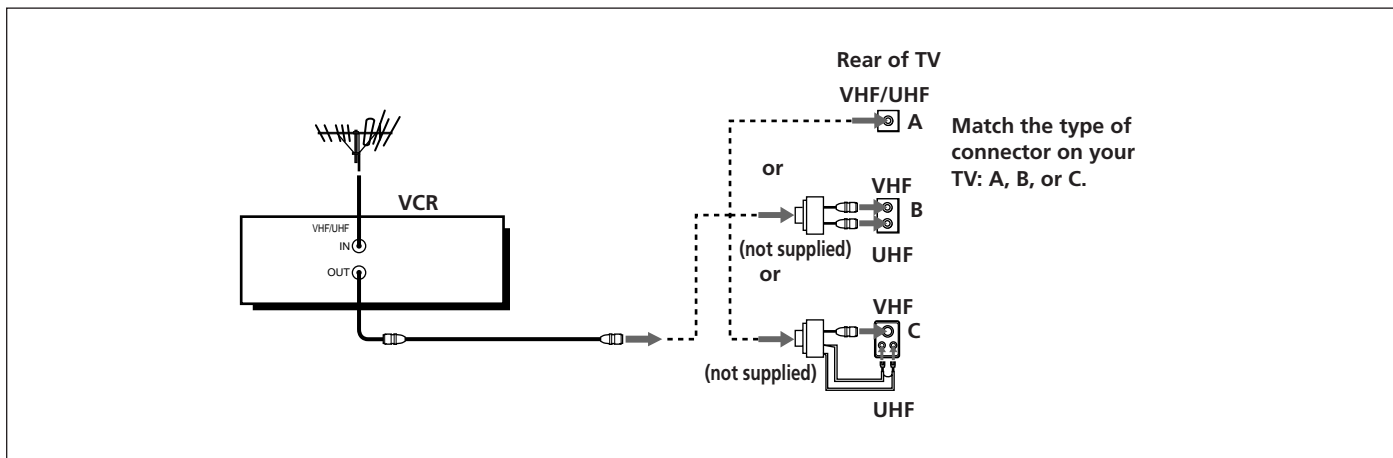

#### B Use this hookup if you're using a VHF-only antenna (you get channels 2–13 only)

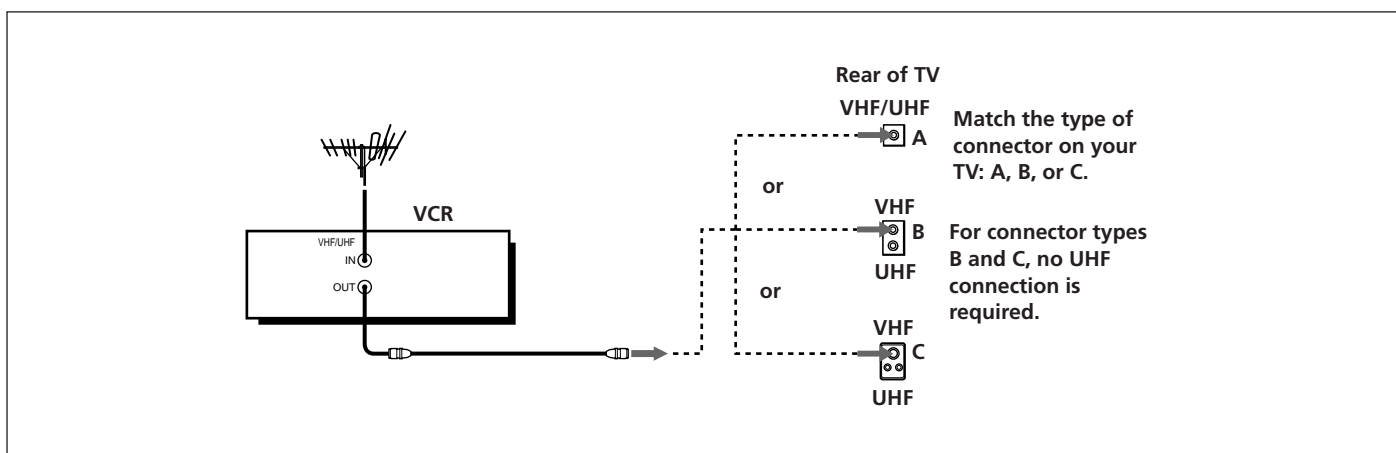

#### If you cannot connect your antenna cable to the VCR directly

If your antenna cable is a flat cable (300-ohm twin lead cable), attach an external antenna connector (not supplied) so you can connect the cable to the VHF/UHF IN connector. If you have separate cables for VHF and UHF antennas, you should use a U/V band mixer (not supplied). For details, see page 92.

## Step 5 TV antenna or cable hookups (continued)

### Hookup 3: VCR setup

- 1 Set the RF UNIT switch to CH 3 or CH 4, whichever channel is not used in your area. If both are used, set the switch to either channel.  
For details, see page 92. If you made V connection (from page 12), you can skip this step.

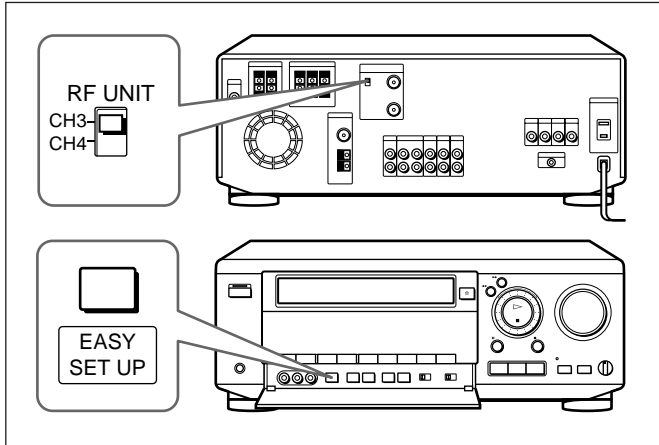

- 2 Press EASY SET UP on the VCR.

- 1 The CLOCK SET menu appears. Set the date and time and press EXECUTE. For details, see page 33.

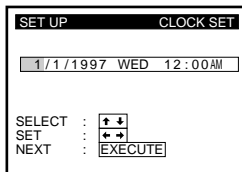

- 2 The CABLE BOX CONTROL menu appears. Select OFF and press EXECUTE. For details, see page 35.

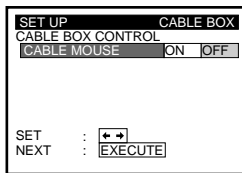

- 3 The TUNER PRESET menu appears. Set ANTENNA/ CABLE to ANT and press EXECUTE. For details, see page 39.

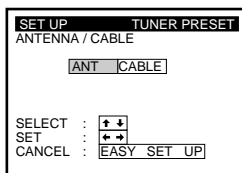

- 4 The AUTO PRESET starts.

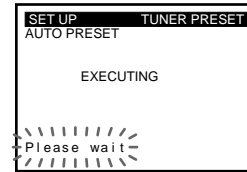

- 5 After completing AUTO PRESET, the CENTER MODE selection menu appears. Select the center mode, and press EXECUTE. For details, see page 30.

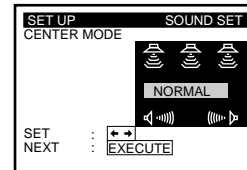

- 6 The TEST TONE selection menu appears. Set the volume of the center and rear speakers and press EXECUTE. For details, see page 31.

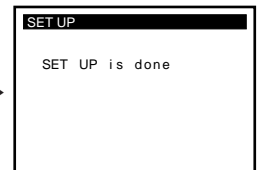
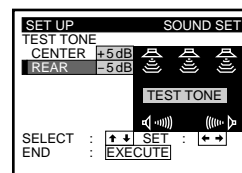
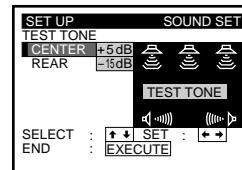

Normal display

## Hookup 3: VCR Plus+ channel setup

- 1 Find the VCR Plus+ Channel Listing in your program guide. For details, see page 43.
- 2 If the channels in the program guide are different from the channels that you actually use on your TV, set the channels that are different as follows. For details, see page 44.

- 1 Press MENU and select VHS MENU.

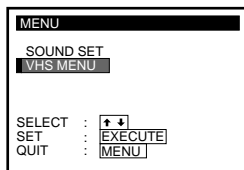

- 2 Select SET VCR Plus+ CHANNELS.

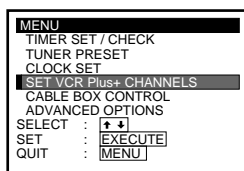

- 3 Enter the program guide channel, then the channel you use on your TV.

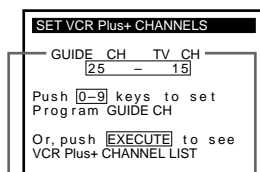

Program guide channel

Your actual TV channel

- 4 Press EXECUTE.

## Hookup 4

### Incompatible cable box with many scrambled channels

#### Recommended use

Use this hookup if your cable company cannot supply a cable box that is compatible with the VCR's cable box control feature, and your cable system scrambles all or most channels.

#### What you can do with this hookup

- Record any channel by selecting the channel on the cable box

#### What you can't do

- Record with the cable box turned off
- Record one channel while watching another channel
- Select channels directly on the VCR

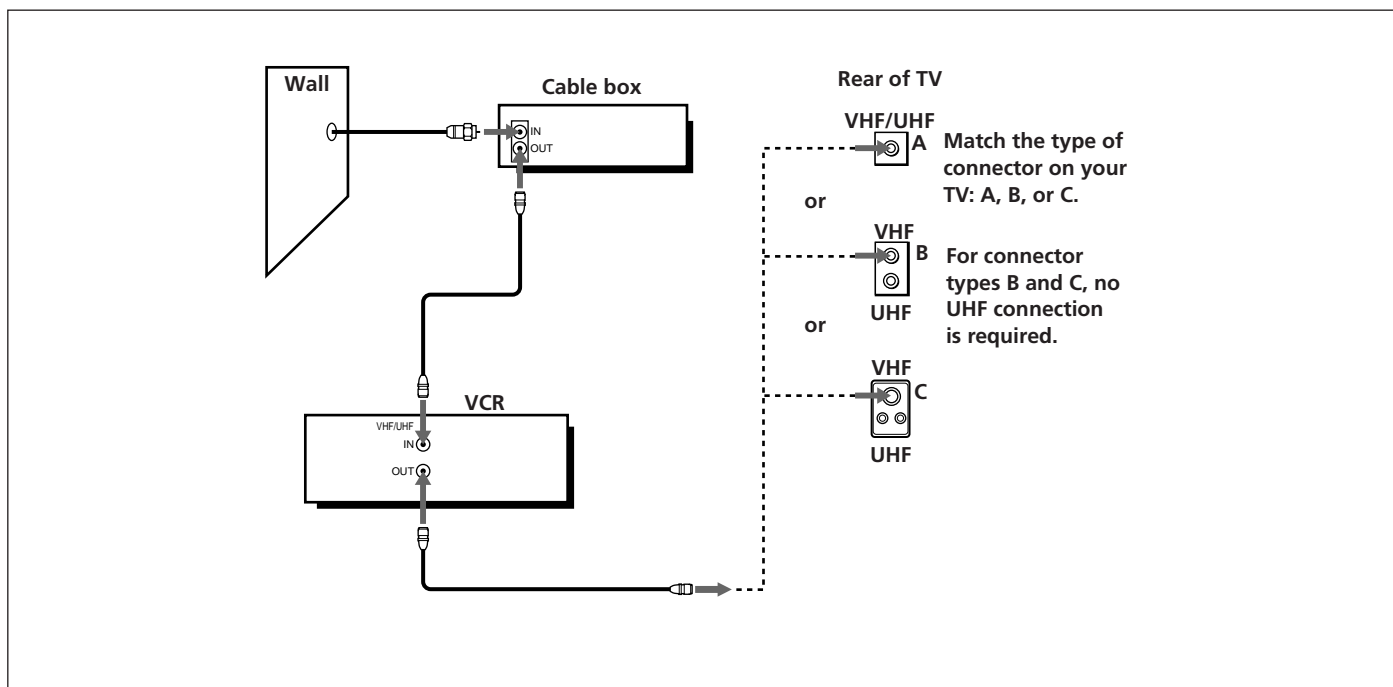

## Hookup 4: VCR setup

- 1 Set the RF UNIT switch to CH 3 or CH 4, whichever channel is not used in your area. If both are used, set the switch to either channel.  
For details, see page 92. If you made V connection (from page 12), you can skip this step.

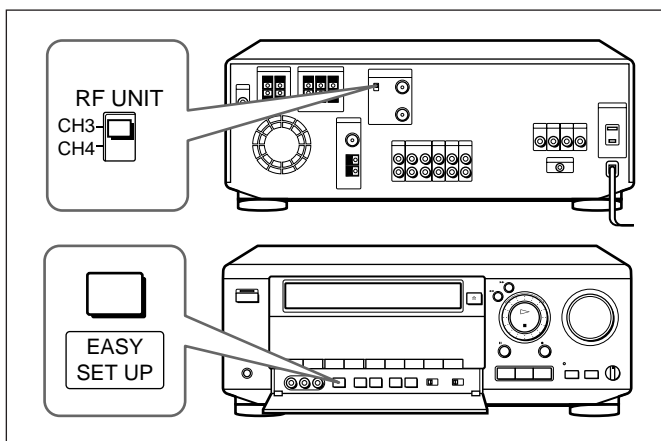

- 2 Turn on your cable box.

- 3 Press EASY SET UP on the VCR.

- 1 The CLOCK SET menu appears. Set date and time and press EXECUTE. For details, see page 33.

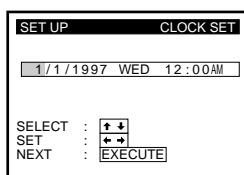

- 2 The CABLE BOX CONTROL menu appears. Select OFF and press EXECUTE. For details, see page 35.

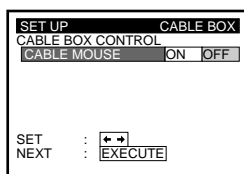

- 3 The TUNER PRESET menu appears. Set ANTENNA/CABLE to ANT and press EXECUTE. For details, see page 39.

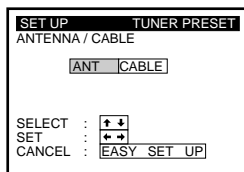

- 4 The AUTO PRESET starts.

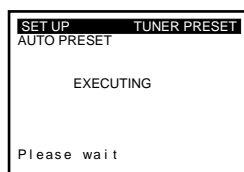

- 5 After completing AUTO PRESET, the CENTER MODE selection menu appears. Select the center mode, and press EXECUTE. For details, see page 30.

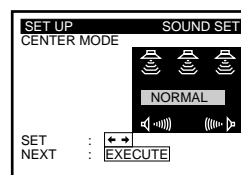

- 6 The TEST TONE selection menu appears. Set the volume of the center and rear speakers and press EXECUTE. For details, see page 31.

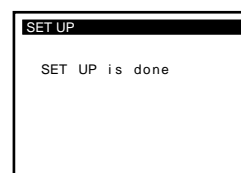
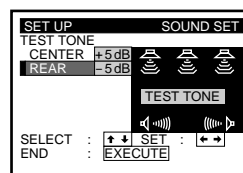
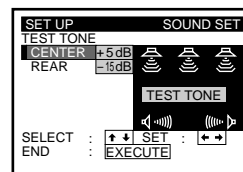

Normal display

## Step 5 TV antenna or cable hookups (continued)

### Hookup 4: VCR Plus+ channel setup

- 1 Find the VCR Plus+ Channel Listing in your program guide. For details, see page 43.
- 2 Enter all the channels you want to record and the cable box output channel (usually 2, 3, or 4). For details, see page 44.
  - 1 Press MENU and select VHS MENU.

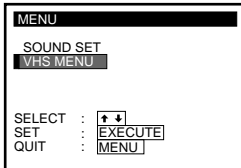

- 2 Select SET VCR Plus+ CHANNELS.

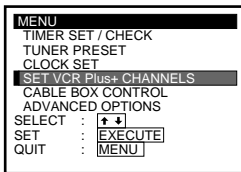

- 3 Enter the program guide channel, then the cable box output channel.

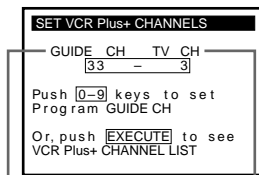

Program guide channel

Cable box output channel

- 4 Press EXECUTE.



## Hookup 5

### DSS (Digital Satellite System) receiver

#### Recommended use

Use this hookup if you have a DSS receiver. It allows the VCR's cable box control feature to control the channel on the DSS receiver, simplifying the recording process. A list of compatible DSS receivers is on page 37.

DSS (Digital Satellite System) is a satellite broadcast that provides superior digital-quality video and crisp digital-quality audio. A variety of program packages are available through your program providers. It also has program guides that are sorted by program categories.

#### What you can do with this hookup

- Record any channels using the VCR's cable box control feature to select channels on the DSS receiver.

#### What you can't do

- Record with the DSS receiver turned off
- Record any channels from cable or an antenna (To record channels from cable or an antenna, turn off the cable box control feature.)
- Use a cable box
- Record programs with VCR Plus+

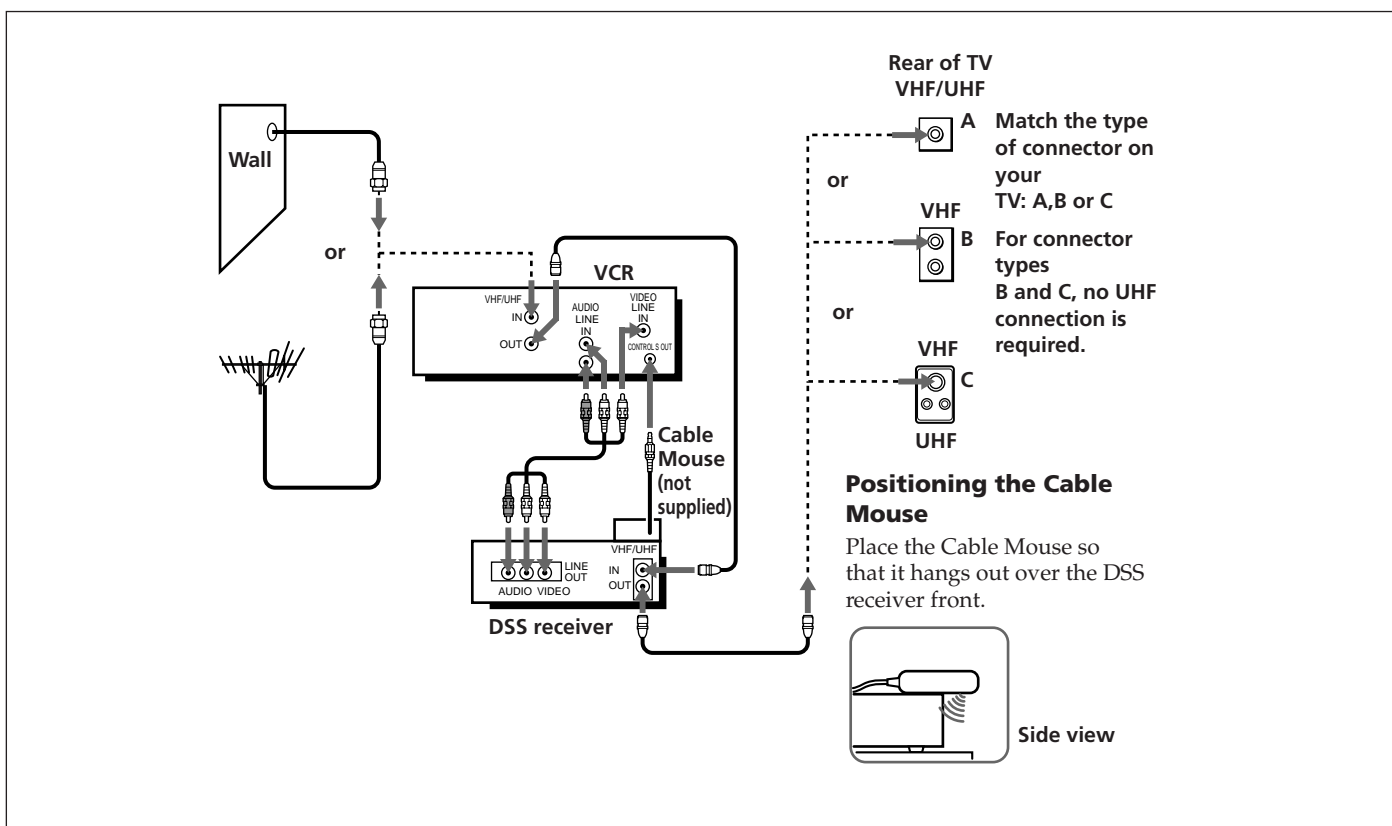

## Step 5 TV antenna or cable hookups (continued)

### Hookup 5: VCR setup

- 1 Set the RF UNIT switch to CH 3 or CH4, whichever channel is not used in your area. If both are used, set the switch to either channel.  
For details, see page 92. If you made V connection (from page 12), you can skip this step.

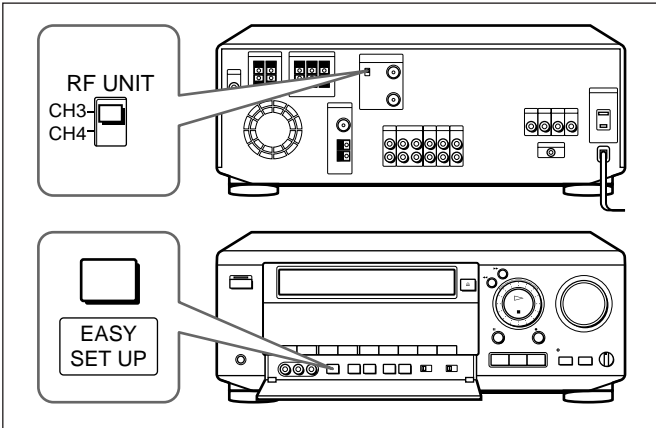

- 2 Turn on your DSS receiver.

- 3 Press EASY SET UP on the VCR.

- 1 The CLOCK SET menu appears. Set the date and time and press EXECUTE. For details, see page 33.

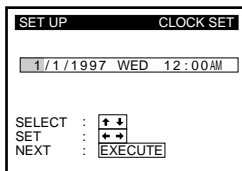

- 2 The CABLE BOX CONTROL menu appears. Select ON. For details, see page 35.

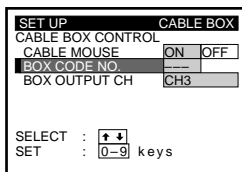

- 3 Enter your DSS receiver code number and press CURSOR ↓.  
For details, see page 35.

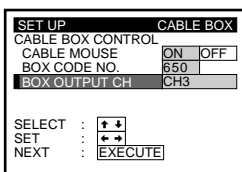

- 4 Set your DSS receiver output channel (BOX OUTPUT CH) to LINE and press EXECUTE.

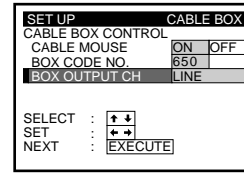

- 5 The CENTER MODE selection menu appears. Select the center mode and press EXECUTE. For details, see page 30.

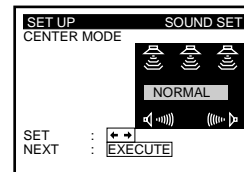

- 6 The TEST TONE selection menu appears. Set the volume of the center and rear speakers and press EXECUTE. For details, see page 31.

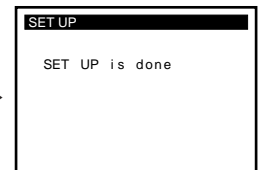
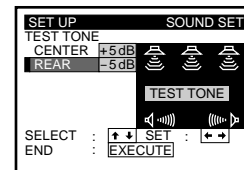
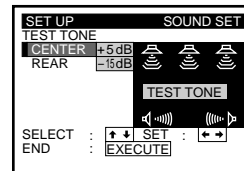

Normal display

### Notes

To successfully record a program from the DSS receiver, proceed as follows:

- Leave the DSS receiver on all the time.
- Turn off the display (menu screen, channel number, etc.) of the DSS receiver.
- To record or receive locked channels, unlock the channel before the VCR starts recording.
- To set pay-per-view programs in the timer setting, order the pay-per-view program before the VCR starts recording.
- Some programs are copy protected. You cannot record these programs.

## Hookup 6

### Incompatible cable box with only a few scrambled channels, using an A/B switch

#### Recommended use

By using an A/B switch (not supplied), this hookup allows you to record both scrambled and unscrambled channels conveniently.

#### What you can do with this hookup

- Record any unscrambled channel by selecting the channel directly on the VCR (the A/B switch is set to A)
- Record any scrambled channel by selecting the channel on the cable box (the A/B switch is set to B)

#### What you can't do

- Record one scrambled channel while watching another channel (the A/B switch is set to B)

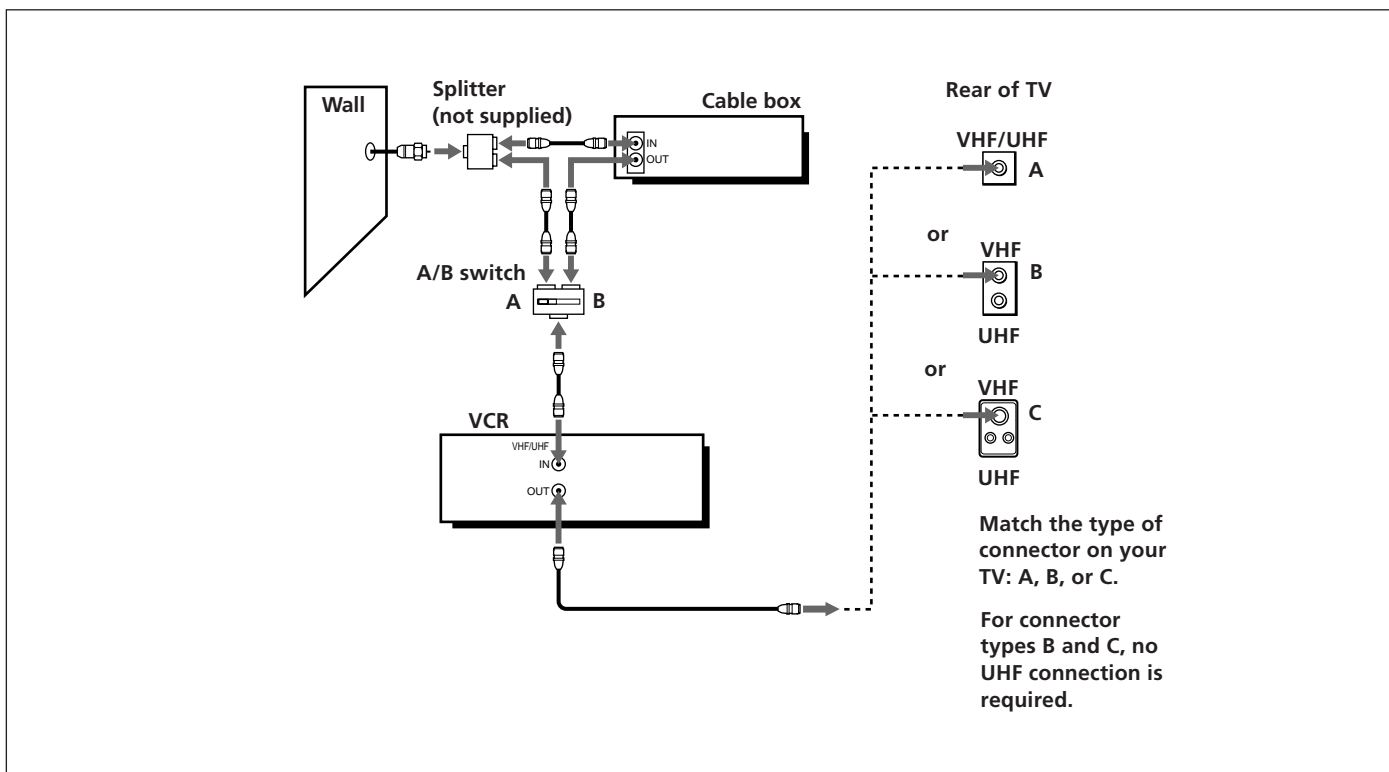

## Step 5 TV antenna or cable hookups (continued)

### Hookup 6: VCR setup

- 1 Set the RF UNIT switch to CH 3 or CH 4, whichever channel is not used in your area. If both are used, set the switch to either channel.  
For details, see page 92. If you made V connection (from page 12), you can skip this step.

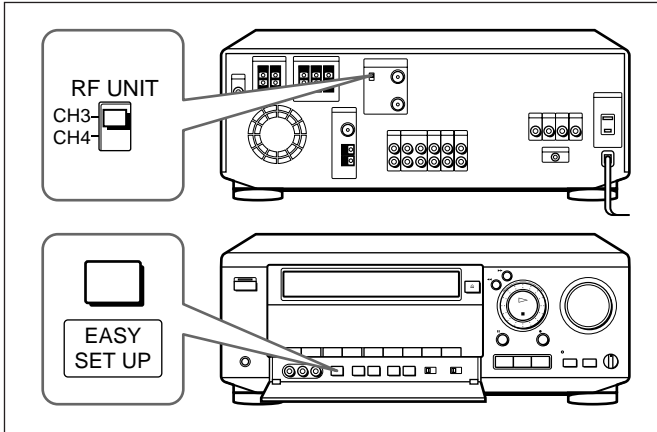

- 2 Set the A/B switch to "A."

- 3 Press EASY SET UP on the VCR.

- 1 The CLOCK SET menu appears. Set the date and time and press EXECUTE. For details, see page 33.

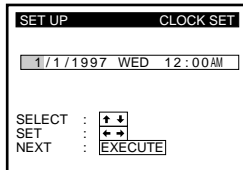

- 2 The CABLE BOX CONTROL menu appears. Select OFF and press EXECUTE. For details, see page 35.

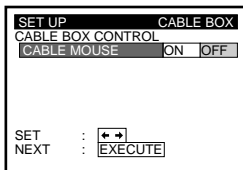

- 3 The TUNER PRESET menu appears. Set ANTENNA/CABLE to CABLE and press EXECUTE. For details, see page 39.

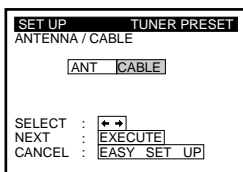

- 4 The AUTO PRESET starts.

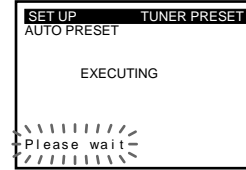

- 5 After completing AUTO PRESET, the CENTER MODE selection menu appears. Select the center mode, and press EXECUTE. For details, see page 30.

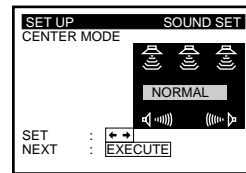

- 6 The TEST TONE selection menu appears. Set the volume of the center and rear speakers and press EXECUTE. For details, see page 31.

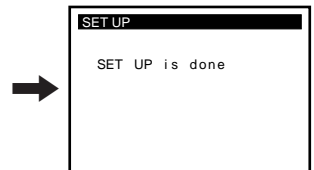
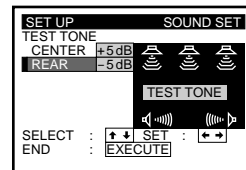
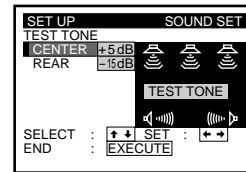

Normal display

- 4 Preset the cable box output channel (usually 2, 3 or 4). For details, see page 35.

- 1 Press MENU. Then press CURSOR ↑/↓ to move the cursor (I) to VHS MENU, and press EXECUTE.

- 2 Select TUNER PRESET.

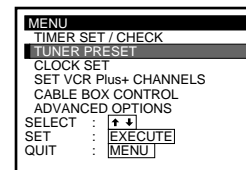

- 3 Enter the cable box output channel. Set MANUAL SET to ADD and press EXECUTE.

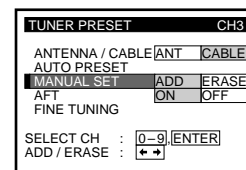

## Hookup 6: VCR Plus+ channel setup

- 1 Find the VCR Plus+ Channel Listing in your program guide. For details, see page 43.
- 2 For unscrambled channels, if the channels in the program guide are different from the channels that you actually use on your TV, set the channels that are different as follows. For details, see page 44.

- 1 Press MENU and select VHS MENU.

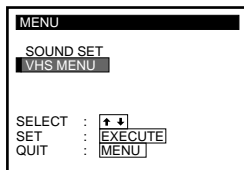

- 2 Select SET VCR Plus+ CHANNELS.

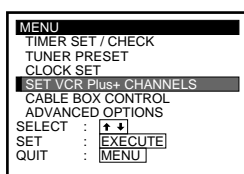

- 3 Enter the program guide channel, then the channel you use on your TV.

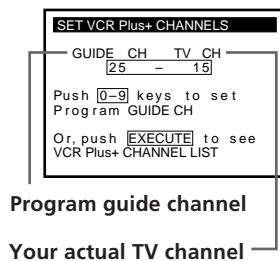

- 4 Press EXECUTE.

- 3 For scrambled channels, enter all the scrambled channels you want to record and the cable box output channel (usually 2, 3, or 4). For details, see page 44.

- 1 Press MENU and select VHS MENU.

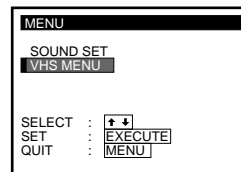

- 2 Select SET VCR Plus+ CHANNELS.

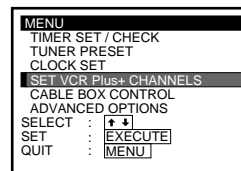

- 3 Enter the program guide channel, then the cable box output channel.

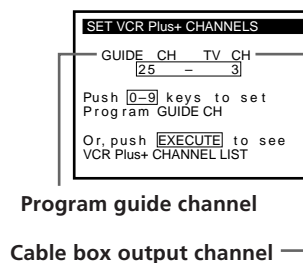

# Adjusting the SOUND SET with EASY SET UP

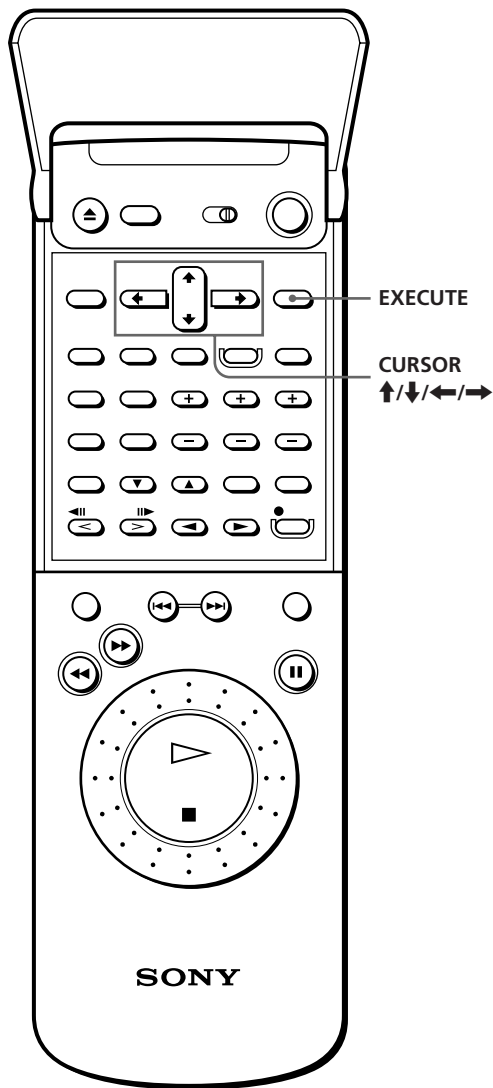

You can set the center mode for the PROLOGIC and THEATER sound fields, and the relative volume level of the center and rear speakers for the PROLOGIC sound field with EASY SET UP. (For sound field explanations, see page 75.)

- 1 Complete each operation other than SOUND SET with EASY SET UP referring to pages 13 to 30.
- 2 After the CENTER MODE selection menu appears, press  $\leftarrow/\rightarrow$  to select the center mode.  
See "Selecting the center mode" on page 32 for details.

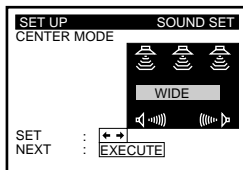

- 3 Press EXECUTE.  
Each speaker emits the test tone in turn (the speaker emitting the test tone is indicated by the red speaker mark).  
Check each speaker's relative volume balance with the test tones.

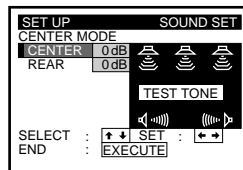

- 4 Press CURSOR  $\uparrow/\downarrow$  to move the cursor (■) to CENTER. Then, press CURSOR  $\leftarrow/\rightarrow$  to increase or decrease the volume of the center speaker so you have an equal volume balance with the other speakers at your listening position.  
If you selected PHANTOM in step 2, skip this step.  
This volume adjustment affects only the PROLOGIC sound field.

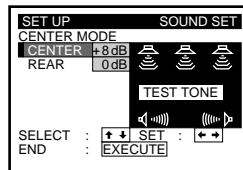

- 5 Press CURSOR  $\uparrow/\downarrow$  to move the cursor (I) to REAR. Then, press CURSOR  $\leftarrow/\rightarrow$  to increase or decrease the volume of the rear speakers so you have an equal volume balance with the other speakers at your listening position.

If you selected 3CH LOGIC in step 2, skip this step.

The surround speakers' volume balance is always even.

This volume adjustment affects only the PROLOGIC sound field.

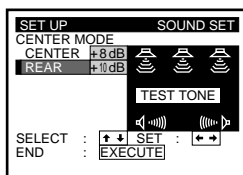

- 6 Press EXECUTE.

After "SET UP is done" screen is appears, a channel appears on the TV screen.

### Tips

- To adjust the relative volume balance between the front left and right speakers, use BALANCE L/R on the unit.
- If you change the speaker configuration, reset the modes. See "Reconfiguring the PROLOGIC and THEATER sound fields" on page 82.
- If you need to further increase the volume of the rear speakers from the maximum level (+10 dB), see "Increasing the maximum rear speaker level" on page 83.

### Selecting the center mode

The center mode is related to the PROLOGIC and THEATER sound fields. (See “Taking advantage of the sound fields” on page 75 for a detailed explanation on sound fields.) You must have rear left and right speakers, or one center speaker other than the front left and right speakers for these sound fields.

You can select NORMAL, WIDE, PHANTOM, or 3CH LOGIC as the center mode. Each mode is designed for a different speaker configuration. Select the most suitable mode considering the following conditions:

#### If you have front and rear speakers, and a small center speaker

Select NORMAL. The center channel bass sound is output from the front speakers. This is because small center speakers cannot reproduce bass sound sufficiently.

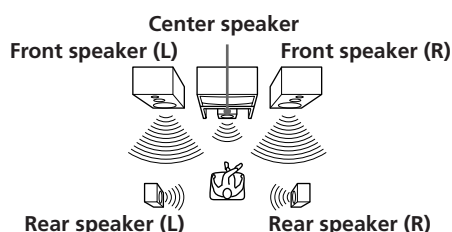

Speaker arrangement display on the TV screen

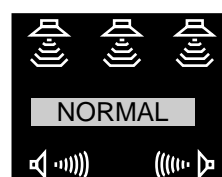

#### If you have front and rear speakers, and a large center speaker

Select WIDE. The combination of this speaker configuration and mode selection is ideal for Dolby Pro Logic Surround sound.

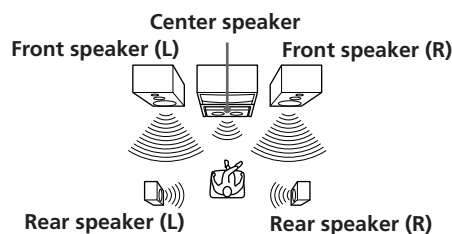

Speaker arrangement display on the TV screen

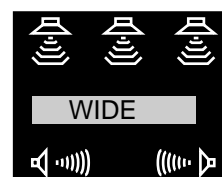

#### If you have only front and rear speakers

Select PHANTOM. The center channel sound is output from the front speakers.

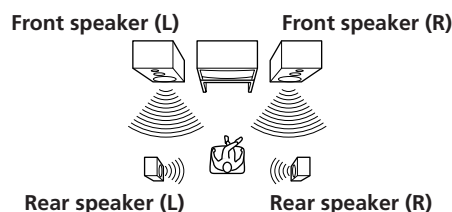

Speaker arrangement display on the TV screen

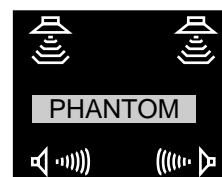

#### If you have only front and center speakers

Select 3CH LOGIC (3 Channel Logic). The rear channel sound is output from the front speakers. You can enjoy some surround sound atmosphere, even if you don't have surround (rear) speakers.

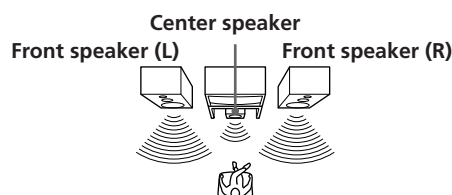

Speaker arrangement display on the TV screen

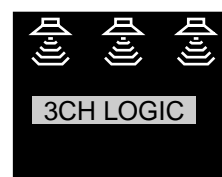



## Setting the clock

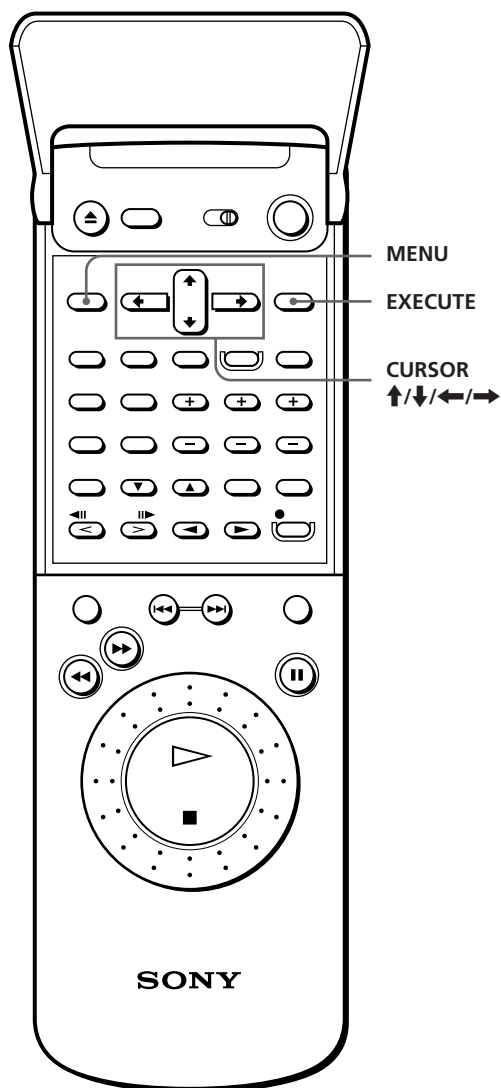

### Tip

- To change the digits during setting, press CURSOR ← to return to the item to be changed, and select the digits using CURSOR ↑/↓.

### Note

- The menu disappears automatically if you don't proceed within a few minutes.

You must set the time and date on the unit to be able to use the timer recording features. If the unit clock was not set in the EASY SET UP procedure, you need to set it manually.

### Before you start...

- Press VHS TUNER.
  - If the TV doesn't turn on, turn it on manually.
  - If connected with only the antenna cable, set the TV to the video channel.

## Setting the clock

- Lift the top cover of the remote commander.

Press MENU. Then press CURSOR ↑/↓ to move the cursor (I) to VHS MENU, and press EXECUTE.

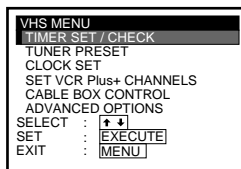

- Press CURSOR ↑/↓ to move the cursor (I) to CLOCK SET and press EXECUTE.

When using the EASY SET UP procedure, skip this step.

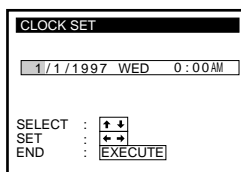

- Set the month using CURSOR ↑/↓.

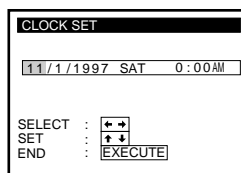

- Press CURSOR → to highlight the date and the day of the week.

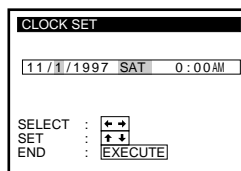

continued

## Setting the clock (continued)

- 5 Press CURSOR  $\uparrow/\downarrow$  to set the date.  
The day of the week is set automatically.

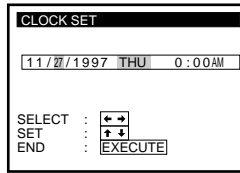

- 6 Set the year, hour, and minutes in sequence using CURSOR  $\rightarrow$  to highlight the item to be set, and CURSOR  $\uparrow/\downarrow$  to select the digits.

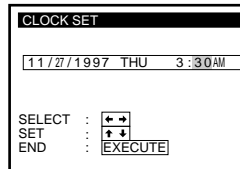

- 7 Press EXECUTE to confirm the setting.

## Setting up cable box control

(Skip this section if you are using Hookup 2, 3, 4 or 6.)

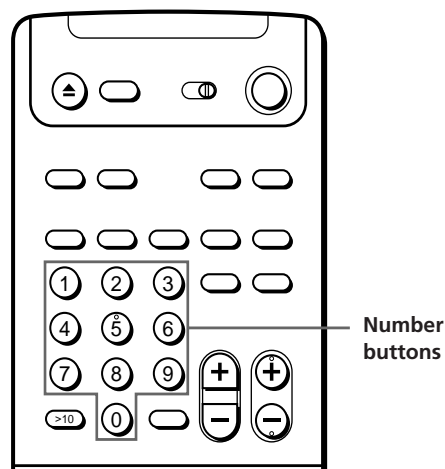
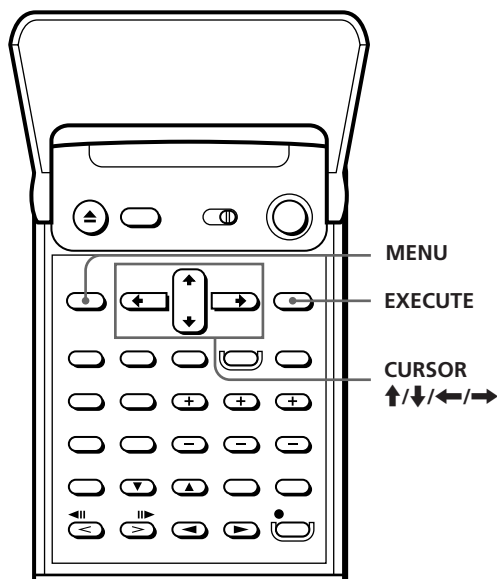

A Cable Mouse is available as an optional accessory for this model. You can order directly from Sony by calling **1-800-488-7669** and asking for Cable Mouse **RM-CM101**. \$14.95 + \$3.00 (shipping, handling and applicable sales tax)

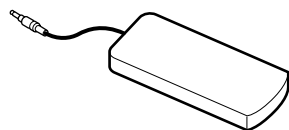

Your unit's VCR includes a cable box control feature that allows the unit's VCR to control most brands of cable boxes/DSS receivers via the Cable Mouse. With cable box control, the unit's VCR controls channels on the cable box/DSS receiver for timer recording. You can also use the VCR's remote commander to change channels on the cable box/DSS receiver whenever the cable box/DSS receiver is turned on even if the unit's VCR is turned off. To use cable box control, you need to connect the Cable Mouse (pages 13 and 25) and set the code number and output channel.

This unit is programmed with codes necessary to control channel selection on most brands of cable boxes at the time this unit was manufactured. If you have a cable box that is incompatible with this VCR, contact your cable operator — they may be able to provide you with a compatible cable box.

- 1 Lift the top cover of the remote commander.  
Press MENU. Then press CURSOR ↑/↓ to move the cursor (█) to VHS MENU, and press EXECUTE.
- 2 Press CURSOR ↑/↓ to move the cursor (█) to CABLE BOX CONTROL and press EXECUTE.  
When using the EASY SET UP procedure, skip this step.

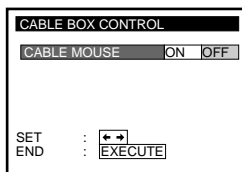

- 3 Press CURSOR ←/→ to select ON.

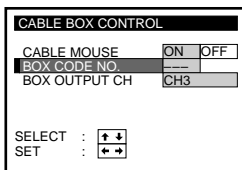

- 4 Close the top cover of the remote commander.  
Press the number buttons to enter the cable box/DSS receiver code number, then press CURSOR ↓.  
Find your cable box/DSS receiver code number from the chart below.

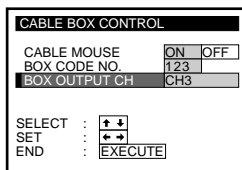

continued

## Setting up cable box control (continued)

- 5 If you want to control a cable box, press CURSOR  $\leftarrow/\rightarrow$  to select the output channel for the cable box, then press EXECUTE.

If you want to control a DSS receiver, select LINE, then press EXECUTE.

### Cable box and DSS receiver brand and the corresponding code numbers

If more than one code number is listed, try entering them one by one, until you come to the correct code for your equipment.

Cable box brand	Code numbers	Cable box brand	Code numbers
ABC	018, 022, 024, 028, 217	Eastern	013, 285
Antronix	218	Electricord	089
Archer	033, 050, 164, 218	Electus	055
BBT	278	Filmnet	454
Cable Star	067	Focus	411
Cabletenna	033	Garrard	164
Cable time	172, 282, 388, 459	GC Electronics	027, 067, 341
Century	164	GE	243, 244
Citizen	164, 326, 327	GEC	097
Clyde Cablevision	097	Gemini	026, 068, 081, 253
Colour Voice	036, 042	General Instrument	022, 287, 487
Comband	243, 244	Hamlin	020, 031, 045, 270, 284
Comtronics	051, 071	Hitachi	022
Decsat	434	Jasco	164, 326
Diamond	046	Jerrold	014, 022, 025, 026, 035, 037, 058, 109, 287, 487
Eagle Comtronics	051		

Cable box brand	Code numbers
Linsay	451
Macom	044
Magnavox	038, 043, 080, 345
Memorex	011
Movie Time	089, 167, 214
Northcoast	325
Novaplex	629
NSC	074, 081, 167, 214
Oak	018, 030, 259
Omniview	382
Panasonic	032, 118
Paragon	011
Philips	036, 038, 039, 040, 041, 042, 071, 301, 345
Philips ECG	253
Pioneer	034, 155, 271, 544
Popular Mechanics	411
Pulsar	011
RCA	032
Realistic	218
Recoton	411
Regal	031, 270, 284, 290
Regency	013
Rembrandt	081
RK	315, 317, 490
Samsung	051, 155
Satbox	386
Scientific Atlanta	017, 019, 028, 288, 338
Seam	521
Sharp	324
Signal	051
Signature	022
SL Marx	051
Spectravision	069
Sprucer	032, 318
Standard Components	107, 166
Starcom	014, 026, 058, 109

Cable box brand	Code numbers
Stargate	026, 051
STS	167
Sylvania	012
T-Cable Teletext	116
Tandy	269
Tatung	108
Teknica	157
Tele +1	454
TeleCaption	232
Teleservice	292
Texscan	012, 107
TFC	321
Timeless	429
Tocom	023, 024, 070
Toshiba	011
Tudi	297
TV86	074
TV COM	018, 030, 259
Uniden	236
Unika	033, 164, 218
United Artists	018
United Cable	014
Universal	033, 050, 067, 088, 089, 164, 202, 218, 333
Videoway	261
Vidtech	255
Viewstar	038, 071, 074, 122, 222, 269, 300
Westminster cable	116
Zenith	011, 065, 536
Zentek	411
Wave Master	576

DSS receiver brand	Code numbers
Sony	650
RCA	577

## Setting up cable box control (continued)

### To ensure correct operation

- Place the Cable Mouse so that it hangs out over the cable box/DSS receiver front.
- Do not place the cable box/DSS receiver on top of the VCR.
- Position the cable box/DSS receiver away from the VCR.
- Point the remote commander at the VCR, not at the cable box/DSS receiver.

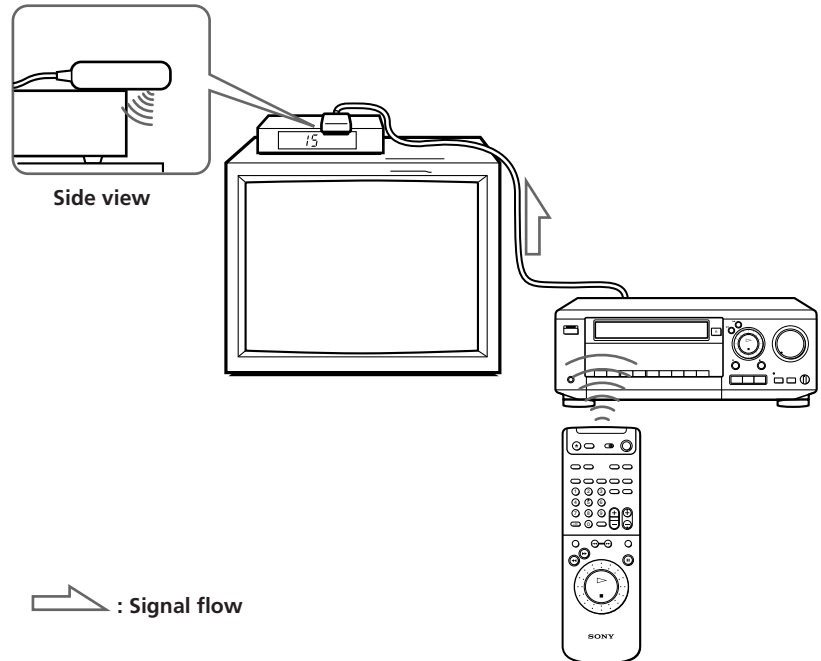

### To check the cable box control setting

- 1 Press CH +/- on the remote commander. Does the channel indicator on the cable box/DSS receiver change? (Point the remote commander at the VCR, not at the cable box/DSS receiver.)
- 2 Press all 10 number buttons (0 to 9) on the remote commander. Does the channel indicator on the cable box/DSS receiver change?

If the answer to both 1 and 2 is "yes," you have made the correct setting.

### If you cannot get your unit's VCR to control the cable box/DSS receiver

- Check that the Cable Mouse is connected to the CABLE BOX CONTROL jack on the VCR.
- Check the position of the Cable Mouse.
- Place the cable box/DSS receiver and VCR away from each other. Do not place the cable box/DSS receiver on top of the VCR.
- Try the setup again making sure to use the correct control code. If the cable box still does not respond, try the other codes that are listed.

If your cable box still does not operate with the Cable Mouse, contact your cable company to see if they can provide you with a compatible cable box.

### Note

- Make sure you turn off the VCR when you plug in or unplug the Cable Mouse. If you unplug the Cable Mouse and plug it in again, turn on the VCR before you use the cable box/DSS receiver control feature.

## Presetting channels

(Skip this section if you are using cable box/DSS receiver control.)

This unit's VCR is capable of receiving VHF channels 2 to 13, UHF channels 14 to 69 and unscrambled CATV channels 1 to 125. First, we recommend that you preset the receivable channels in your area using automatic presetting. Then, if there are any unwanted channels, disable them manually. If you have decided which channels you wish to preset, set them directly using manual presetting.

### Before you start...

- Turn on the VCR and the TV.
- Set the TV to the VCR channel (channel 3 or 4). If your TV is connected to the VCR using V connections, set the TV to video input.
- Press TV/VTR to display the VTR indicator in the VCR's display window.
- Press VHS TUNER so that a channel number appears in the VCR's display window.

### Presetting all receivable channels automatically

- 1 Press MENU. Then press CURSOR  $\uparrow/\downarrow$  to move the cursor (■) to VHS MENU, and press EXECUTE.
- 2 Press CURSOR  $\uparrow/\downarrow$  to move the cursor (■) to TUNER PRESET and press EXECUTE.

When using the EASY SET UP procedure, skip this step.

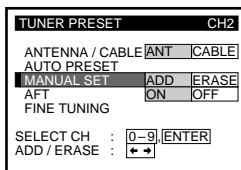

- 3 • To preset cable TV channels:

Press CURSOR  $\leftarrow/\rightarrow$  to set ANTENNA/CABLE to CABLE.

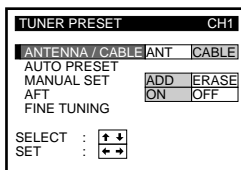

- To preset VHF and UHF channels:

Press CURSOR  $\leftarrow/\rightarrow$  to set ANTENNA/CABLE to ANT.

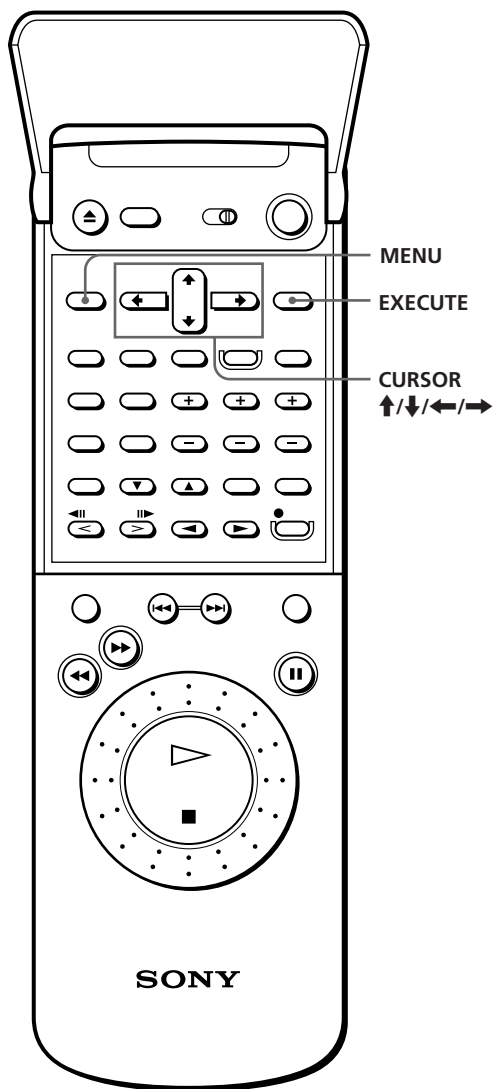
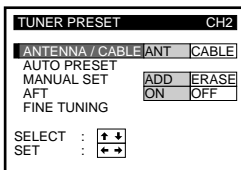

continued

## Presetting channels (continued)

- 4 Press CURSOR  $\uparrow/\downarrow$  to select AUTO PRESET then press EXECUTE.  
All receivable channels are preset in numerical sequence. When no more receivable channels can be found, presetting stops and the picture from the lowest numbered channel is displayed on the TV screen.

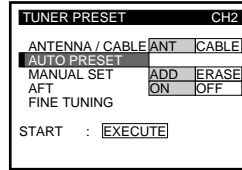

### Tip

- When receiving a VHF, UHF or CATV channel, the display changes as follows each time you press the DISPLAY button.

Channel number, sound field mark and muting mark



No display



## Presetting/disabling channels manually

1 Press MENU. Then press CURSOR  $\uparrow/\downarrow$  to move the cursor (I) to VHS MENU, and press EXECUTE.

2 Select TUNER PRESET.

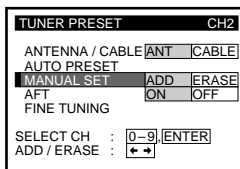

3 • To preset a channel:

1 Press the number buttons to enter the channel number, then press ENTER.

2 Press CURSOR  $\leftarrow/\rightarrow$  to set MANUAL SET to ADD.

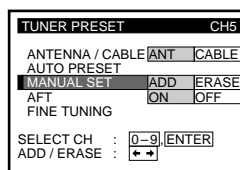

• To disable a channel:

1 Press CH/PRESET +/- to select the channel number.

2 Press CURSOR  $\leftarrow/\rightarrow$  to set MANUAL SET to ERASE.

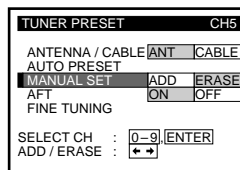

4 Repeat step 3 to preset or disable channels as required, then press EXECUTE.

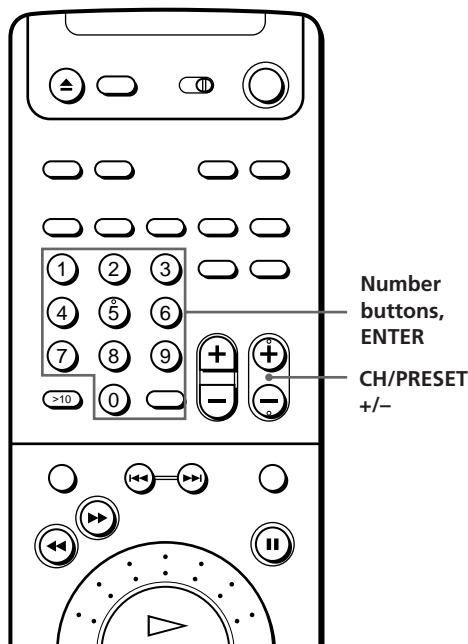
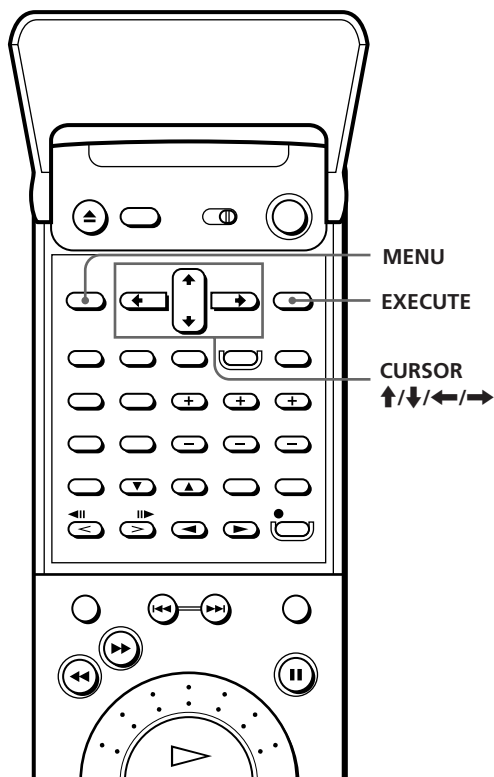

## Presetting channels (continued)

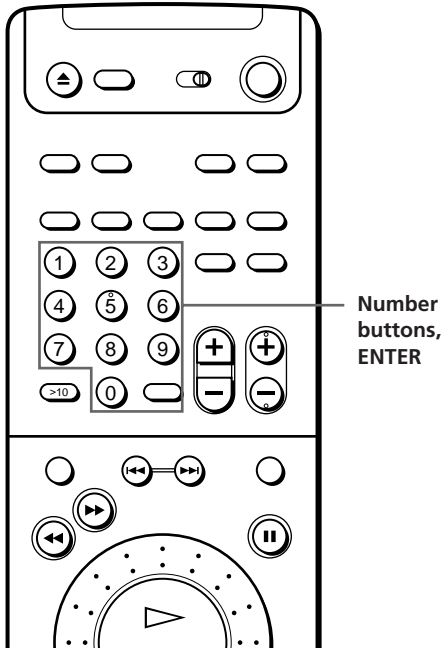
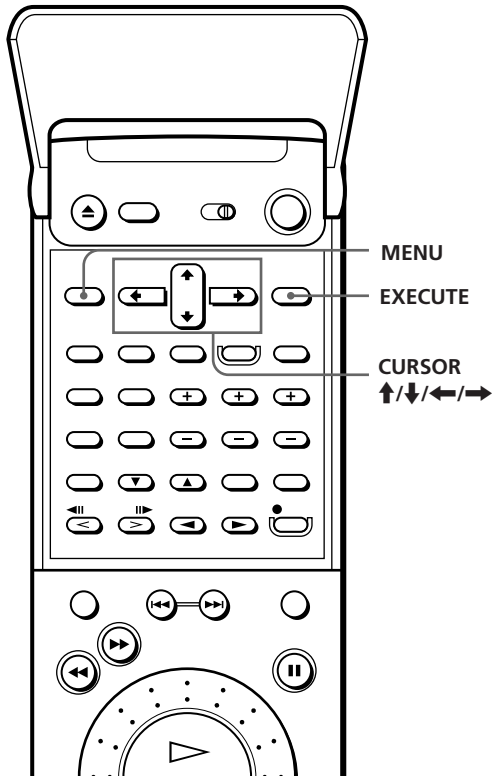

## If the picture is not clear

Normally, the Auto Fine Tuning (AFT) function automatically tunes in channels clearly. If, however, the picture of a channel is not clear, you can also use the manual tuning function.

**1** Press MENU. Then press CURSOR  $\uparrow/\downarrow$  to move the cursor (■) to VHS MENU, and press EXECUTE.

**2** Select TUNER PRESET.

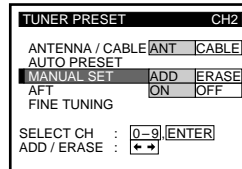

**3** Press the number buttons to select the channel you want to fine-tune, then press ENTER.

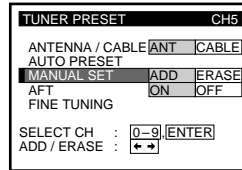

**4** Press CURSOR  $\uparrow/\downarrow$  to select FINE TUNING.

The fine tuning meter appears.

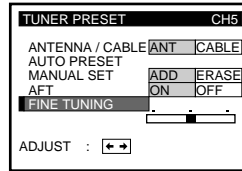

**5** Press CURSOR  $\leftarrow/\rightarrow$  to adjust to a clearer picture.

Note that the AFT setting switches to OFF.

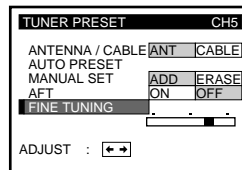

## Setting up VCR Plus+

### How VCR Plus+ works

Whenever you want to record a TV program, all you need to do is look up the program's "PlusCode," a number assigned to each program that's published in the TV section of most newspapers, cable TV listings, and even TV GUIDE magazine. Then, just enter the PlusCode of the program you want and the VCR is automatically programmed to record that show. It's that simple.

#### Example of "PlusCode"

		PlusCode
5:30	<b>14</b> MOVIE — Musical (2hrs.)	<b>33044</b>
	<b>2</b> SPORT — Golf (1hr. 25min.)	<b>42060</b>
	<b>CNN</b> — WS 9974	
6:30	<b>2 3 4</b> DRAMA — Comedy (2hrs.)	<b>17390</b>
	<b>5</b> SCIENCE AND TECHNOLOGY (1hr. 15min.)	<b>73457</b>

### How to set up your unit's VCR

Setting up your VCR involves coordinating the TV channel number (the number you turn to on your TV or VCR to watch a program) with the guide channel (the number that's assigned to that channel in your program guide). To get the guide channel numbers, find the "Channel Line-up Chart" in the program guide for your area that features VCR PlusCodes. It usually looks like the example below.

For each channel your VCR receives, use the Channel Line-up Chart to check that the channel numbers match. For example, if HBO is listed in the Channel Line-up Chart on channel 33, and your VCR receives HBO on channel 5, you need to coordinate these numbers using the following procedure. For channels in which the numbers are the same, you can skip this procedure.

#### Example of "Channel Line-up Chart"

CABLE CH	CABLE TV	VCR Plus+ GUIDE CH
16	<b>AMC</b> American Movie Classics	35
17	<b>BRV</b> Bravo (program grid only)	54
20	<b>CNN</b> Cable News Network	42
21	<b>CSP</b> C-SPAN	28
22	<b>DIS</b> The Disney Channel	53
25	<b>DSC</b> The Discovery Channel	37
34	<b>ESN</b> ESPN	34
35	<b>FAM</b> The Family Channel	47
5	<b>HBO</b> Home Box Office	33
27	<b>LIF</b> Lifetime	46
29	<b>MAX</b> Cinemax	45
30	<b>MTV</b> Music Television	48
31	<b>NIK</b> Nickelodeon	38
38	<b>SC</b> Sports Channel	59
39	<b>SCA</b> Sports Channel America	70
45	<b>SHO</b> Showtime	41
17	<b>TBS</b> TBS SuperStation	43
44	<b>TMC</b> The Movie Channel	58
49	<b>TNN</b> The Nashville Network	49
50	<b>TNT</b> Turner Network Television	52
51	<b>USA</b> USA Network	44

## Setting up VCR Plus+ (continued)

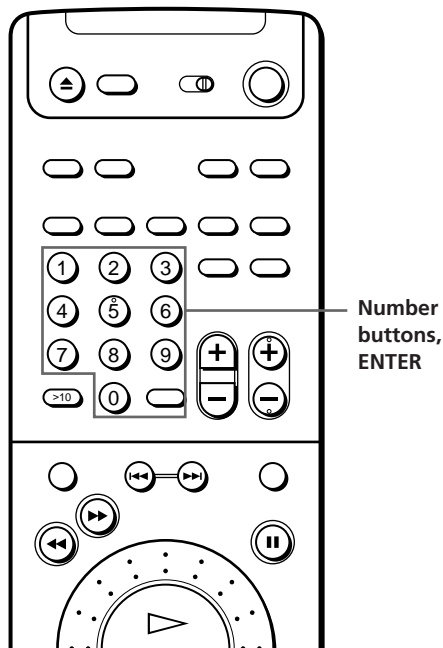
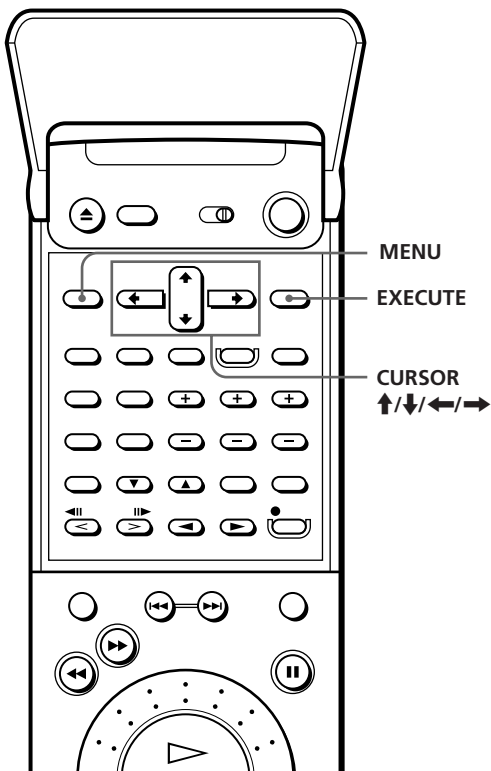

- 1 Press MENU. Then press CURSOR  $\uparrow/\downarrow$  to move the cursor (|) to VHS MENU, and press EXECUTE.
- 2 Move the cursor (|) to SET VCR Plus+ CHANNELS and press EXECUTE.

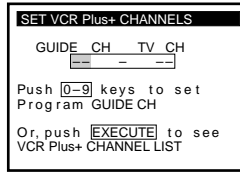

- 3 Enter the channel number assigned in the program guide and press ENTER.

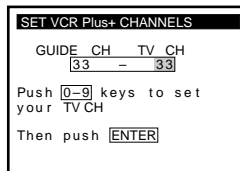

- 4
  - If you made Hookup 1, 2 or 3: Enter the actual number on your TV (and VCR) and press ENTER.
  - If you made Hookup 4: Enter the cable output channel (usually 2, 3 or 4) and press ENTER.
  - If you made Hookup 6: Enter the actual number on your TV (and VCR) for an unscrambled channel and press ENTER. For a scrambled channel, enter the cable box output channel (usually 2, 3 or 4) and press ENTER.

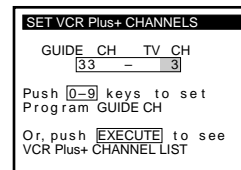
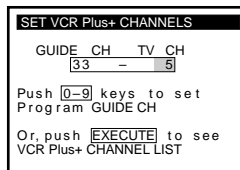

- 5 Repeat steps 3 and 4 for each channel whose numbers don't match.
- 6 When you have set all channels, press EXECUTE to confirm your channel settings.

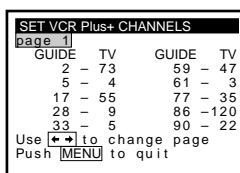

- 7 When you've finished, press MENU to exit.

## Presetting radio stations

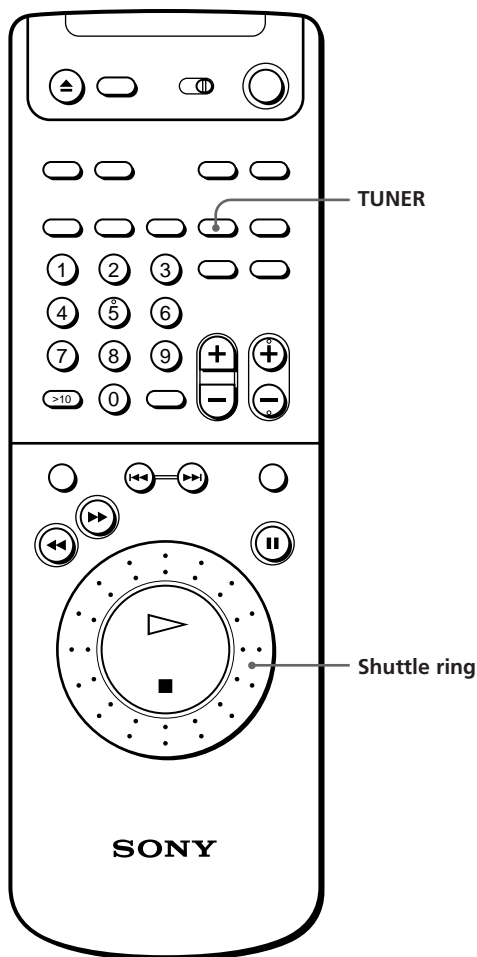
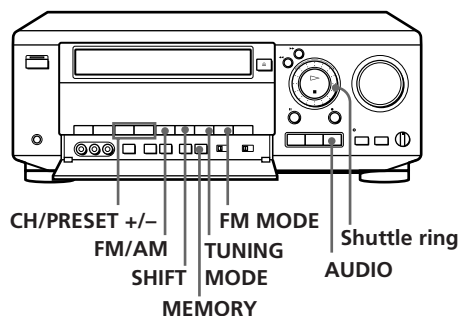

You can preset up to 30 FM or AM stations so that you don't have to tune in the station every time. The preset numbers are combined 3 characters (A, B, C) and numbers (0-9). For example, you can store a station as preset number A1, B6, or C9, etc.

- 1 Press AUDIO repeatedly until "FM" or "AM" appears (or press TUNER on the remote).
- 2 Press TUNING MODE repeatedly until "AUTO" appears.

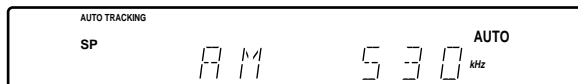

- 3 Press FM/AM to select "FM" or "AM".

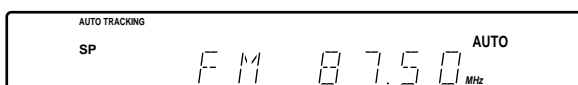

- 4 Turn the Shuttle ring clockwise or anticlockwise. Turn it clockwise for a higher station number; turn it anticlockwise for a lower one. The frequency indication changes and scanning stops when the unit tunes in a station.
- 5 Press MEMORY. The MEMORY menu appears on the TV screen while MEMORY appears in the display window.

MEMORY		FM 102.50MHz	
A1	FM 90.00	A6	
A2		A7	FM 110.00
A3	AM 1690	A8	
A4	FM 89.50	A9	FM 105.50
A5		A0	

SELECT : +/- [SHIFT]  
SET : [MEMORY]

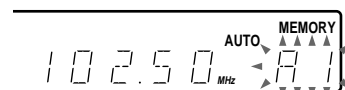

- 6 Press SHIFT to select a character. Each time you press SHIFT, the character "A", "B" or "C" appears in the display window. If "MEMORY" disappears, start again from step 3.
- 7 While MEMORY is displayed, press the CH/PRESET +/- to select the number and press MEMORY.

MEMORY		FM 102.50MHz	
A1	FM 90.00	A6	
A2	FM 102.50	A7	FM 110.00
A3	AM 1690	A8	
A4	FM 89.50	A9	FM 105.50
A5		A0	

- 8 Repeat steps 2 through 5 to preset other stations.

### Tips

- If the STEREO indicator remains off, press FM MODE when an FM stereo broadcast is received.
- If an FM stereo program is distorted, the STEREO indicator flashes. Press FM MODE to change to monaural (MONO). You will not have the stereo effect but the distortion will be reduced. To return to stereo mode, press this button again.

continued

## Presetting radio stations (continued)

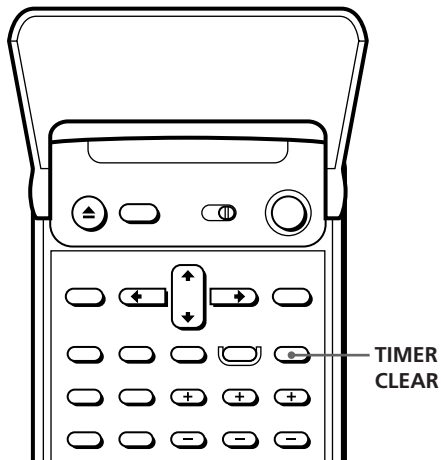
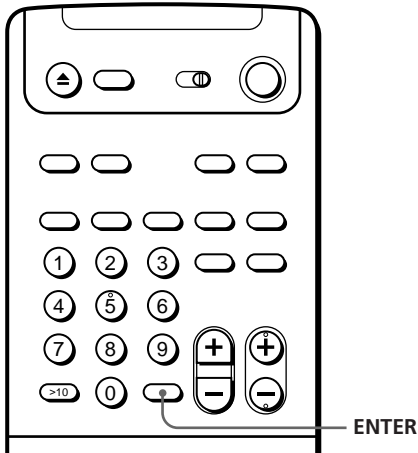

### To tune in a station with a weak signal

- 1 Press TUNING MODE repeatedly until "MANUAL" appears in step 2.
- 2 Press FM/AM to select "FM" or "AM".
- 3 Turn the Shuttle ring clockwise or anticlockwise until your desired station is tuned in.

### To check preset stations

If you don't know which stations are preset on which numbers, you can display the list of preset stations on the TV screen. Press ENTER. Then, press SHIFT while FM/AM TUNER LIST appears.

FM / AM TUNER LIST				
A1	FM	90.00	A6	
A2	FM	102.50	A7	FM 110.00
A3	FM	1690	A8	
A4	FM	89.50	A9	FM 105.50
A5			A0	
SET	:	+ -	SHIFT	
QUIT	:	ENTER		

### To change a preset station

Preset a new station on the number you want to change.

### To erase the memory of the preset number

- 1 Press CH/PRESET +/- to select the preset number you want to erase.
- 2 Press MEMORY.
- 3 While MEMORY is displayed, press TIMER CLEAR.

MEMORY				
A1	FM	90.00	A6	
A2	FM	102.50	A7	
A3	FM	1690	A8	
A4	FM	89.50	A9	FM 105.50
A5			A0	
Preset data is erased				

# Basic VCR / Radio Operations

## Playing a video tape

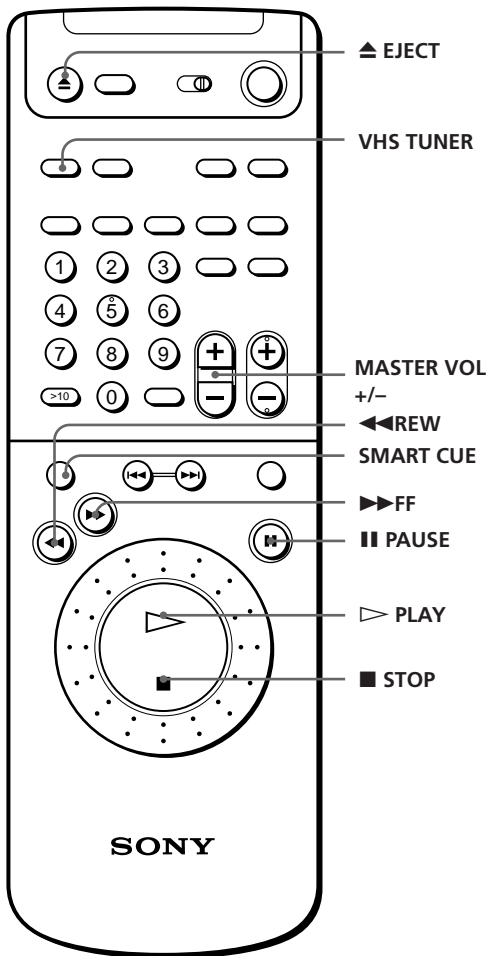
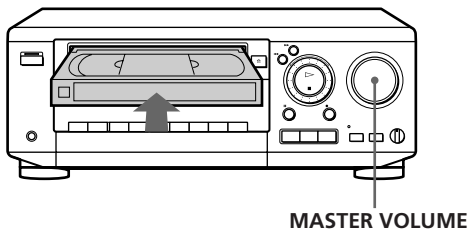

### Tips

- The unit turns on if you insert a tape while the power is off.
- The counter resets to "0H00M00S" whenever a tape is inserted.

### Note

- The unit's sound won't be reproduced through the TV unless the speaker connectors or TAPE/MD REC OUT jacks are connected to the TV. Normally, the speakers connected to the unit reproduce the sound.

### Before you start...

- Turn MASTER VOLUME to the leftmost position (0) to avoid damaging your speakers.

## 1 Press VHS TUNER.

- If the TV doesn't turn on, turn it on manually.
- If connected with only the antenna cable, set the TV to the video channel.

## 2 Insert a video tape.

The unit's VCR starts playing automatically if you insert a tape with its safety tab removed.

## 3 Press ▷ PLAY.

When the tape reaches the end, it will rewind automatically.

## 4 Press MASTER VOL +/- on the remote commander to adjust the volume.

### Additional tasks

To	Press
Stop play	■ STOP
Pause play	PAUSE
Resume play after pause	PAUSE or ▷ PLAY
Search forward	During playback, press and hold ►► FF. To resume normal playback, release the button.
Search backward	During playback, press and hold ◄◄ REW. To resume normal playback, release the button.
Fast-forward the tape	►► FF during stop
Rewind the tape	◄◄ REW during stop
Eject the tape	▲ EJECT

### To skip playback

You can skip a portion of playback you don't want to watch such as a commercial and restart playback by pressing a single button.

Press SMART CUE during playback of a scene you want to skip. The VCR starts searching.

Press SMART CUE again when you find the scene you want to watch. The VCR stops searching, rewinds a few seconds, then resumes normal playback.

continued

## Basic VCR / Radio Operations

### Playing a video tape

(continued)

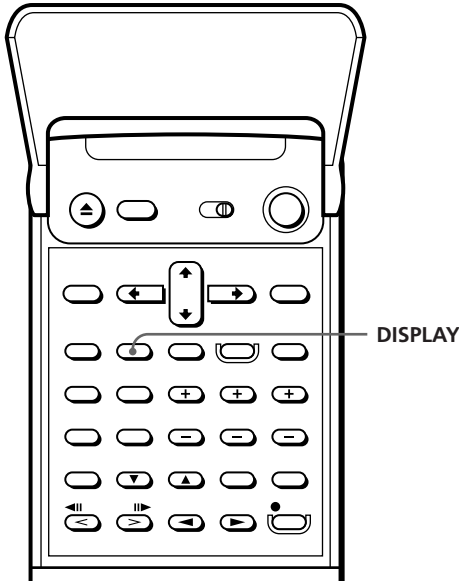
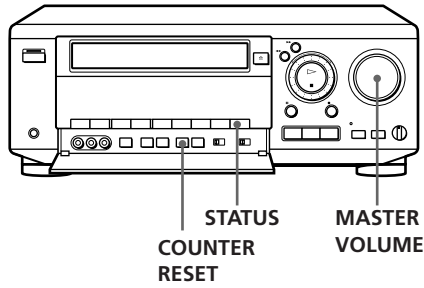

#### Notes

- Tapes recorded in the LP mode on other VCRs can be played back on this VCR but the picture quality cannot be guaranteed.
- The counter stops counting when it comes to an unrecorded portion.
- If the muting mark doesn't appear on the TV screen, press DISPLAY.

#### To use the time counter

At the point on the tape that you want to find later, press COUNTER RESET. The counter in the display window resets to "0H00M00S."

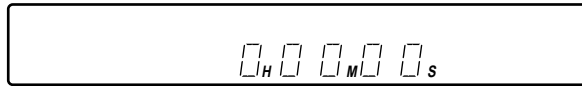

To display the time counter on the TV screen, press DISPLAY.

#### To change the information in the display window

Press STATUS repeatedly.

Each press changes the indication in the following way:

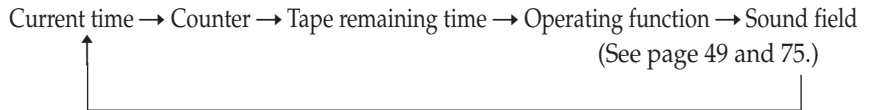

Regardless of the selected indication, the operational function and selected sound field appears in the display window momentarily. To display only the indication selected with the STATUS button, set INDICATION in the ADVANCED OPTIONS to OFF (see page 89).

#### To mute the sound

Press MUTING on the remote commander or unit. The muting mark appears on the TV screen if the on-screen display function is on, and the MASTER VOLUME indicator on the unit flashes.

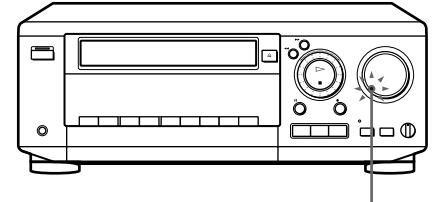

To restore the sound, press MUTING again.



# Using the pre-programmed sound fields

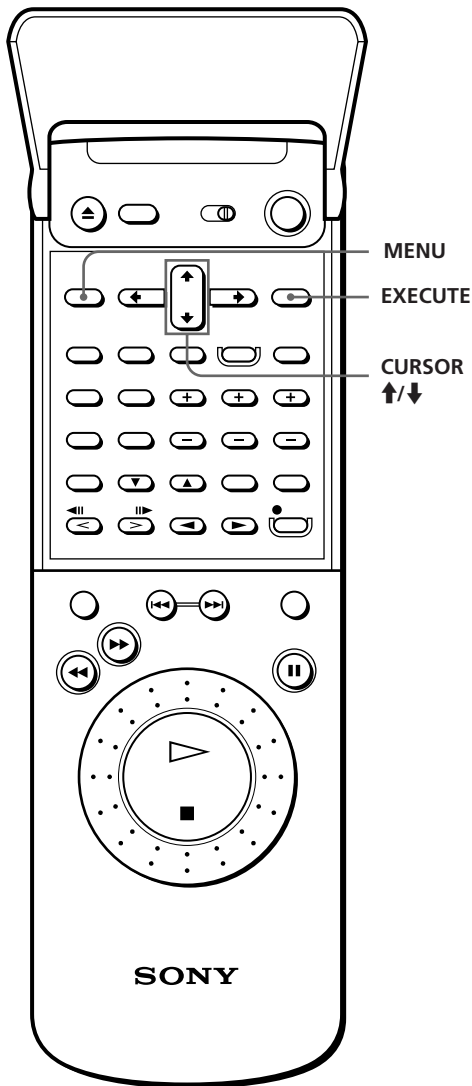

You can enjoy the surround sound effect by simply selecting one of the pre-programmed sound fields according to the type of playback source.

- 1 Lift the top cover of the remote commander.**  
While playing any source, press **MENU**. Then press **CURSOR ↑/↓** to move the cursor (I) to **SOUND SET**, and press **EXECUTE**.

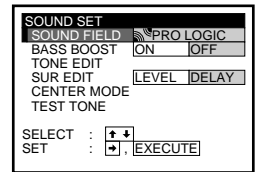

- 2 Press CURSOR ↑/↓ to move the cursor (I) to SOUND FIELD and press EXECUTE (or CURSOR →).**  
The current sound field mark is highlighted.

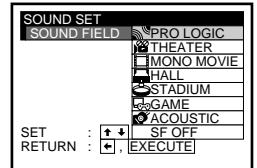

- 3 Press CURSOR ↑/↓ to highlight the most suitable sound field for the playback source.**  
See "Taking advantage of the sound fields" on page 75 for details on selecting a suitable sound field.

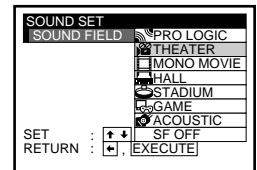

- 4 Press EXECUTE (or CURSOR ←).**  
The customizing menu for the selected sound field appears.  
If you want to customize the sound field, see "Customizing the sound fields" on page 78.

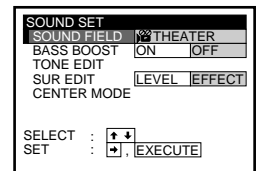

- 5 Press MENU to return to the original screen.**  
The selected sound field mark appears on the TV screen if the display function is on (see "To check the remaining tape length" on the next page).



# Recording TV programs

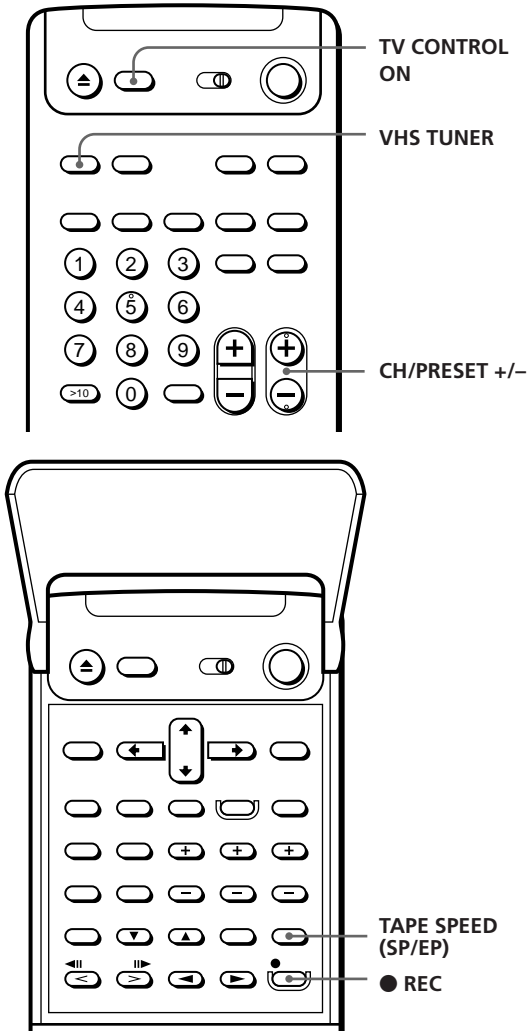

- Tips**
- To select a channel, you can use the number buttons and ENTER on the remote commander.
  - You can select a video source (e.g. a DSS receiver, etc.) connected to the LINE IN jacks by pressing VHS LINE repeatedly, until "LINE" is displayed on the TV screen.
  - Information about the tape appears on the TV screen, but the information won't be recorded on the tape.
  - If you don't want to watch TV while recording, you can turn off the TV. When using a cable box, be sure to leave it on.
  - You can enjoy watching or listening to another input source even while recording.

**Note**

- The display does not appear during still (pause) mode or slow-motion playback.

- 1 Press VHS TUNER.**
  - If the TV doesn't turn on or the LINE 1 is not selected on the TV, turn it on manually.
  - If connected with only the antenna cable, set the TV to the video channel.
  - To record from a cable box, turn it on.

- 2 Insert a tape with its safety tab in place.**

- 3 Press CH/PRESET +/- to select the channel you want to record.**



- 4 Lift the top cover of the remote commander and press TAPE SPEED to select the tape speed, SP or EP.**

EP provides recording time three times as long as SP, however, SP produces better picture and audio quality.



- 5 Press ● REC to start recording.**

**To stop recording**

Press ■ STOP.

**To check the remaining tape length**

Press DISPLAY. The display function turns on. The white bar indicates the approximate length of tape remaining.

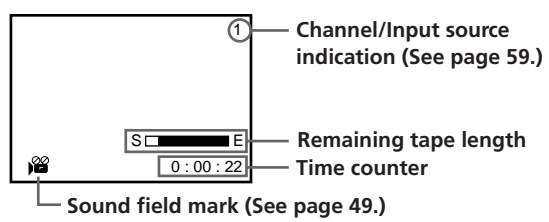

**To watch another TV program while recording**

- Press TV/VTR to clear the VTR indicator in the display window.
- If the TV is connected to the MONITOR VIDEO OUT jacks, set the TV to TV input; if not, skip this step.
- Press TV CONTROL ON on the remote commander.
- Select another channel on the TV.

**To save a recording**

To prevent accidental erasure, break off the safety tab as illustrated. To record on that tape again, cover the tab hole with adhesive tape.

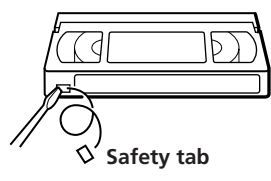

# Recording TV programs using VCR Plus+

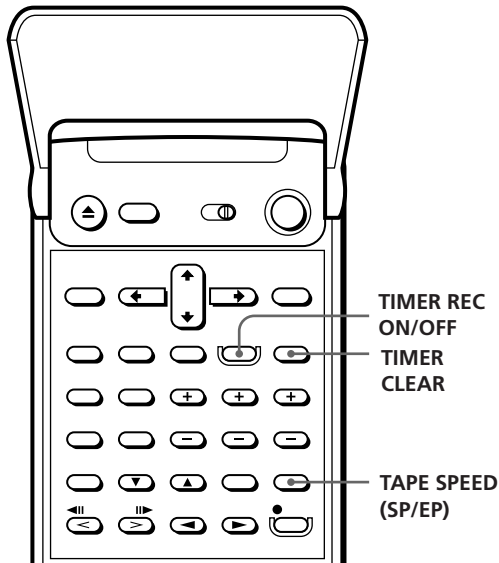
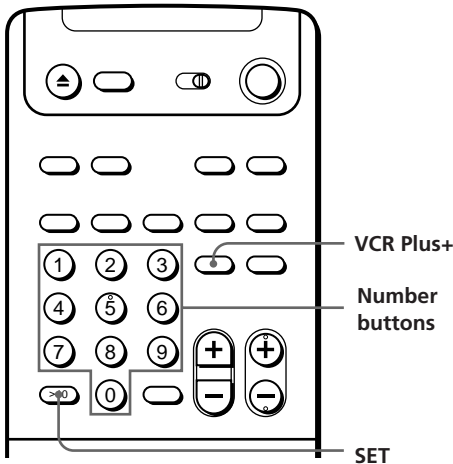

### Tip

- To cancel the procedure, press VCR Plus+ before pressing ENTER.

### Note

- If the unit's VCR beeps repeatedly, the Plus Code is incorrect.

Just enter the program's Plus Code listed in the TV program guide. The date, times and channel number of that program are set automatically. You can preset up to eight programs at a time.

### Before you start...

- Check that the unit's clock is set to the correct time.
- Insert a tape with its safety tab in place. Make sure the tape is longer than the total recording time.
- Press VHS TUNER.
  - If the TV doesn't turn on or the LINE 1 is not selected on the TV, turn it on manually.
  - If connected with only the antenna cable, set the TV to the video channel manually.
  - When using a cable box, turn it on.

## 1 Press VCR Plus+.

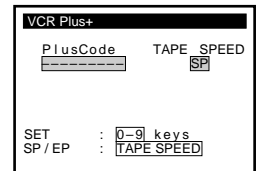

## 2 Press the number buttons to enter the program's Plus Code.

If you make a mistake, press TIMER CLEAR and enter the correct number.

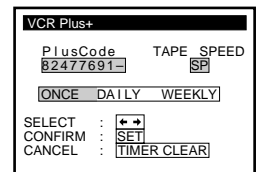

## 3 Lift the top cover of the remote commander, then press TAPE SPEED to select SP or EP.

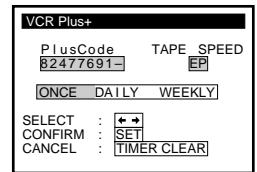

## 4 Press CURSOR ←/→ to select ONCE, DAILY or WEEKLY.

To record	Select
Only once	ONCE
Everyday Monday to Friday	DAILY
Once a week	WEEKLY

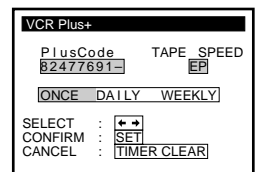

continued

## Recording TV programs using VCR Plus+ (continued)

### 5 Close the top cover of the remote commander, then press SET to confirm.

The date, start and stop times, channel number, and tape speed appear on the TV screen.

If the information is not correct, press TIMER CLEAR to cancel the setting.

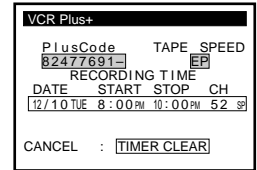

### 6 To enter another setting, repeat steps 1 through 5.

### 7 Press TIMER REC ON/OFF.

The TIMER indicator appears in the display window and the unit's VCR stands by for timer recording.

The picture switches to the video source.

To record from a DSS receiver or other source, leave the connected equipment switched on.

#### Tip

- TIMER REC on the unit has the same function as TIMER REC ON/OFF on the remote commander.

#### Note

- If you selected any audio input while watching the unit's VCR picture before the unit's VCR enters recording standby, only the picture switches to the TV after you press TIMER REC ON/OFF.

#### To stop recording

To stop the unit's VCR while recording, press TIMER REC ON/OFF.

#### To record satellite broadcasts

If you connect a DSS receiver and the unit, you can record satellite programs.

- 1 Turn on the DSS receiver.
- 2 Press VHS LINE (if the DSS receiver is connected to the unit with the LINE jacks).
- 3 On the DSS receiver, select the satellite program for which you wish to make a timer setting.
- 4 Repeat the steps 1 through 7 starting on page 51.
- 5 Keep the DSS receiver turned on until the unit's VCR finishes the timer recording.

## Using the unit after setting the timer

You can use the unit to select and listen to or watch other input sources (see “Audio/Video Equipment Operations” from page 59) during timer recording standby and timer recording.

To use the unit’s VCR before a timer recording begins, just press **TIMER REC ON/OFF**. The **TIMER** indicator turns off and the unit’s VCR switches on. Remember to press **TIMER REC ON/OFF** again to reset the timer after using the unit’s VCR.

You can also do the following VCR related tasks while the unit’s VCR is recording:

- Reset the counter.
- Display tape information on the TV screen.
- Check the timer settings.

# Setting the timer manually

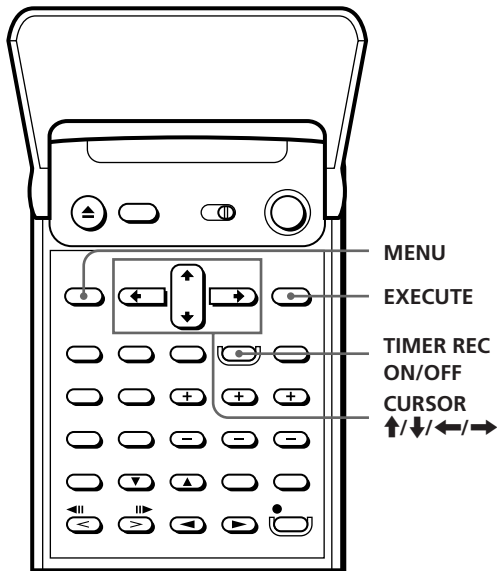
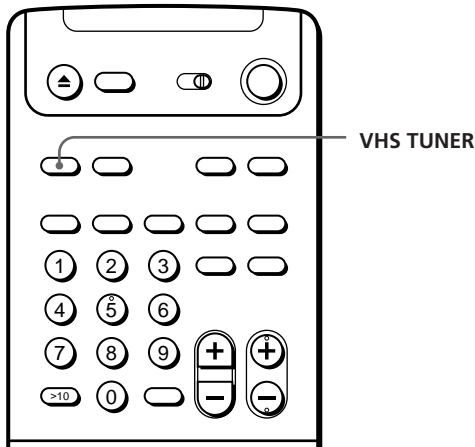

### Tip

- To set the channel, you can also use the CH/PRESET +/– or number buttons.

### Notes

- “TIMER” flashes in the display window if you press TIMER REC ON/OFF with no tape inserted.
- You can only timer record TV programs from the unit’s VCR tuner, or LINE input sources.

If VCR Plus+ is not available in your area, follow the instructions below to set the timer to record programs.

### Before you start...

- Check that the unit’s clock is set to the correct time.
- Insert a tape with its safety tab in place. Make sure the tape is longer than the total recording time.
- Press VHS TUNER.
  - If the TV doesn’t turn on or the LINE 1 is not selected on the TV, turn it on manually.
  - If connected with only the antenna cable, set the TV to the video channel.
- When using a cable box, turn it on.

## 1 Lift the top cover of the remote commander.

Press **MENU**. Then press **CURSOR**  $\uparrow/\downarrow$  to move the cursor (I) to **VHS MENU**, and press **EXECUTE**.

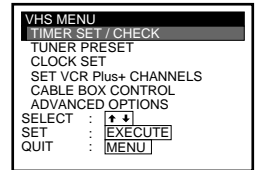

## 2 Press **CURSOR** $\uparrow/\downarrow$ to move the cursor (I) to **TIMER SET/CHECK**, then press **EXECUTE**.

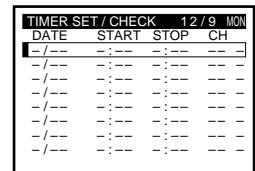

## 3 Set the date, start and stop times, channel number, and tape speed:

- Press **CURSOR**  $\rightarrow$  to highlight each item in turn.
- Press **CURSOR**  $\uparrow/\downarrow$  to set each item. To correct a setting, press **CURSOR**  $\leftarrow$  to return to that setting and reset.

To record the same program every day or on the same day every week, press **CURSOR**  $\downarrow$  while the date is highlighted. For details, see “Daily/weekly recording” on the next page.

To record from a DSS receiver or other source connected to the LINE jacks, press **CURSOR**  $\uparrow/\downarrow$  in the “CH” column repeatedly to display “LINE.”

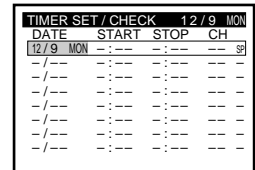

## 4 Press **CURSOR** $\rightarrow$ to confirm the setting.

The cursor (I) appears at the beginning of the line. To enter another setting, move the cursor to the next line and repeat step 3.

**Note**

- If you selected any audio input while watching the unit's VCR picture before the unit's VCR enters recording standby, only the picture switches to the video source after you press **TIMER REC ON/OFF**.

---

**5 Press EXECUTE.**

**6 Press TIMER REC ON/OFF.**

The **TIMER** indicator appears in the display window and the unit's VCR stands by for recording.

The picture and sound switch to the video source.

To record from a DSS receiver or other source, leave the connected equipment switched on.

---

**To stop recording**

To stop the unit's VCR while recording, press **TIMER REC ON/OFF**.

**Daily/weekly recording**

In step 3 above, press **CURSOR ↓** in the "DATE" column to select the recording pattern. Each time you press **CURSOR ↓**, the indication changes as shown below.

the current date → **SUN-SAT** → **MON-SAT** → **MON-FRI** → **EVERY SAT** .....  
→ **EVERY MON** → **EVERY SUN** → **1 month later** → (dates count down)  
→ the current date

**Using the unit after setting the timer**

You can use the unit to select and listen to or watch other input sources (see "Audio/Video Equipment Operations" from page 59) during timer recording standby and timer recording.

To use the unit's VCR before a timer recording begins, just press **TIMER REC ON/OFF**. The **TIMER** indicator turns off and the unit's VCR switches on. Remember to press **TIMER REC ON/OFF** again to reset the timer after using the unit's VCR.

You can also do the following VCR related tasks while the unit's VCR is recording:

- Reset the counter.
- Display tape information on the TV screen.
- Check the timer settings.

# Checking/changing/ cancelling timer settings

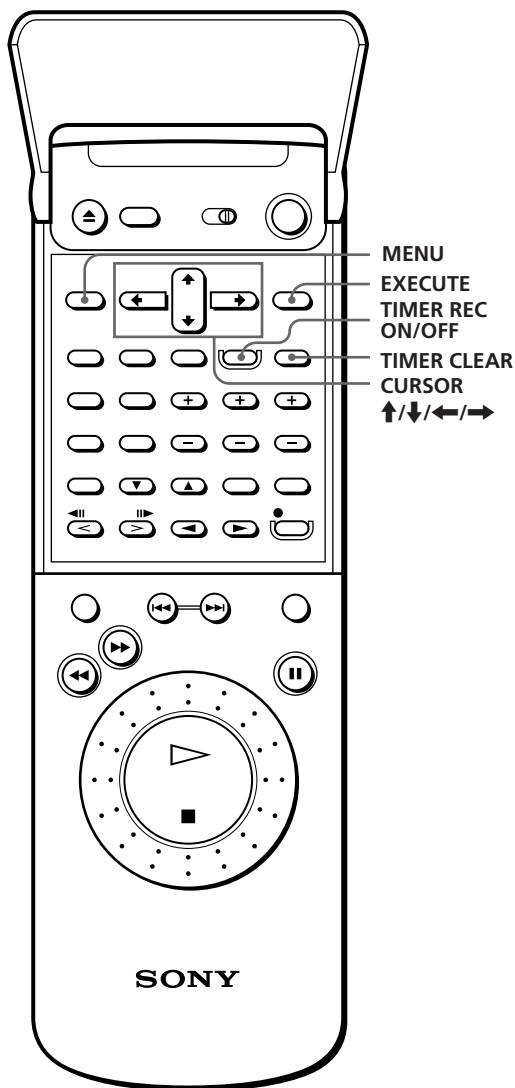

## Before you start...

- When the unit is in timer recording standby mode, press TIMER REC ON/OFF to clear the TIMER indicator.
- Press VHS TUNER.
  - If the TV doesn't turn on or the LINE 1 is not selected on the TV, turn it on manually.
  - If connected with only the antenna cable, set the TV to the video channel.

### 1 Lift the top cover of the remote commander.

Press **MENU**. Then press **CURSOR**  $\uparrow/\downarrow$  to move the cursor (I) to **VHS MENU**, and press **EXECUTE**.

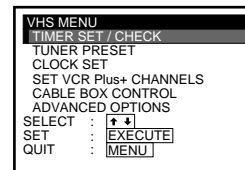

### 2 Press **CURSOR** $\uparrow/\downarrow$ to move the cursor (I) to **TIMER SET/CHECK**, then press **EXECUTE**.

- If you want to change a setting, go on to the next step.
- If you do not need to change the settings, press EXECUTE, then press TIMER REC ON/OFF to return to recording standby.

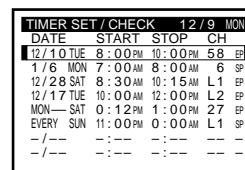

### 3 Press **CURSOR** $\uparrow/\downarrow$ to select the setting you want to change or cancel:

- To change the setting, press **CURSOR**  $\leftarrow/\rightarrow$  to highlight the item you want to change, then press **CURSOR**  $\uparrow/\downarrow$  to reset it. Then, press **CURSOR**  $\rightarrow$  repeatedly until the cursor (I) appears at the beginning of the line.
- To cancel the setting, press **TIMER CLEAR**.

### 4 Press **EXECUTE**.

If any settings remain, press **TIMER REC ON/OFF** to return to recording standby.



### When the timer settings overlap

The program that starts first has priority and the second program starts recording only after the first program has finished. If the programs start at the same time, the program listed first in the menu has priority.

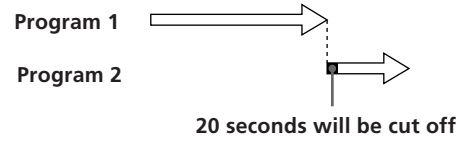
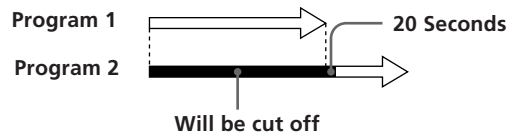



# Audio/Video Equipment Operations

## Selecting the equipment

You can control the connected audio and video equipment with this remote commander. Before operating any equipment, press the function button corresponding to the equipment. Note that all equipment must be made by Sony to control with the remote commander.

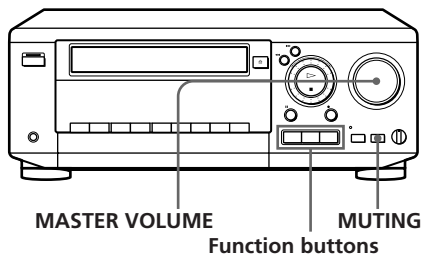
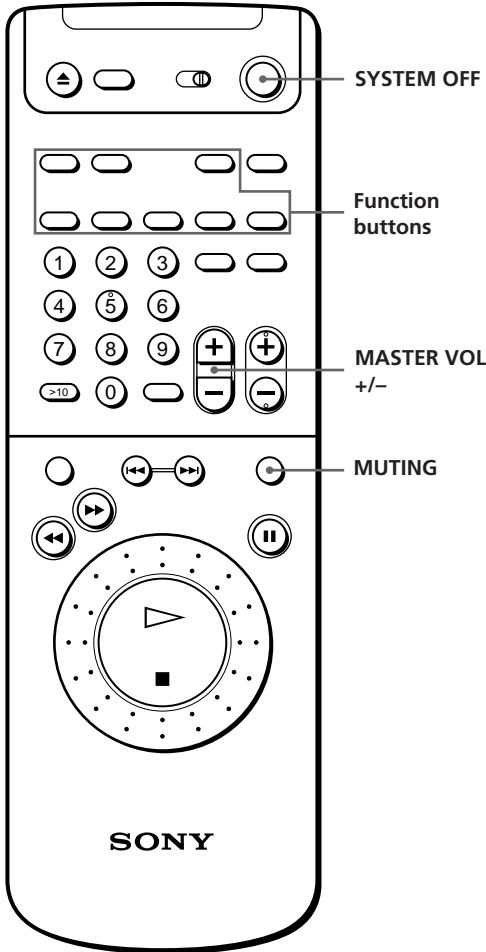

### Controlling the function buttons

The function buttons of the remote commander have the following three roles.

- Turning on the unit and related piece of equipment (excluding audio components).
- Switching the input source.
- Switching the remote commander to operate the selected equipment (see the sections for controlling each piece of equipment from page 62 to 74).

To change the input source, you can also use the function buttons on the unit.

The following tables show the relationship between the function buttons (on the remote commander and unit) and the input source.

#### Function buttons on the remote commander (SYSTEM CONTROL/FUNCTION)

Press	The following indication appears on the TV screen	And the unit's input switches to the
VHS TUNER	channel number	Unit's VCR
VHS LINE	LINE	LINE (VIDEO IN, AUDIO L/R IN) jacks
VIDEO1	VIDEO1	VIDEO1 (VIDEO IN, AUDIO L/R IN) jacks
VIDEO2	VIDEO2	VIDEO2 INPUT (VIDEO, AUDIO L/R) jacks
TV*1	(TV)*2	TV (VIDEO, AUDIO L/R IN) jacks
CD	CD	CD (AUDIO L/R IN) jacks
TUNER	TUNER	Unit's FM/AM tuner
TAPE/MD	TAPE/MD	TAPE/MD (AUDIO L/R IN) jacks

\*1 If the TV is connected to the unit with only the antenna cable, the unit's speakers do not reproduce the sound even if you press this button. When you use the TV tuner, press TV CONTROL ON (see "Controlling other TVs with the remote commander" on page 65).

\*2 "TV" usually doesn't appear on the TV screen. If another monitor is connected to the MONITOR VIDEO OUT jack, "TV" appears on the monitor screen.

## Selecting the equipment (continued)

### Function buttons on the unit (FUNCTION)

Press the following button repeatedly	Until the following indication appears on the TV screen	Then the unit's input switches to the
VHS	Channel number	Unit's VCR
	LINE	LINE (VIDEO IN, AUDIO L/R IN) jacks
VIDEO* <sup>1</sup>	(TV)* <sup>2</sup>	TV (VIDEO IN, AUDIO L/R IN) jacks
	VIDEO1	VIDEO1 (VIDEO IN, AUDIO L/R IN) jacks
	VIDEO2	VIDEO2 INPUT (VIDEO, AUDIO L/R) jacks
AUDIO	TUNER	Unit's FM/AM tuner
	CD	CD (AUDIO L/R IN) jacks
	TAPE/MD	TAPE/MD (AUDIO L/R IN) jacks

\*<sup>1</sup> If the TV is connected to the unit with only the antenna cable, the unit's speakers do not reproduce the sound even if you select the TV with this button. When you use the TV tuner, press TV CONTROL ON (see "Controlling other TVs with the remote commander" on page 65).

\*<sup>2</sup> "TV" usually doesn't appear on the TV screen. If another monitor is connected to the MONITOR VIDEO OUT jack, "TV" appears on the monitor screen.

## Watching a picture while listening to audio equipment

If you change the input from a video source to an audio source, the sound will be switched to the audio source but the picture continues to be output. The last selected video source's indicator remains lit in the display window.

### Note

- When the TV is selected, no picture appears in the display window.



## Before operating audio/video equipment

- Connect all the components securely and correctly as indicated on pages 6 through 10.
- Turn MASTER VOLUME to the leftmost position (0) to avoid damaging the speakers.
- Note that you may not be able to control all the functions of the equipment described in these Operating Instructions with the remote commander. In this case, refer to the operating instructions of each piece of equipment.  
If there is any function you cannot control with the remote commander, use the remote control of each piece of equipment.

## Using the operations common to all equipment

### To increase or decrease the volume

Press MASTER VOL +/- on the remote commander, or turn MASTER VOLUME on the unit clockwise or anticlockwise.

### To mute the sound

Press MUTING. To restore the sound, press it again.

### To turn off the whole system

Press SYSTEM OFF.

#### Note

- You cannot turn off the power of the non-Sony TVs.

# Controlling VCRs

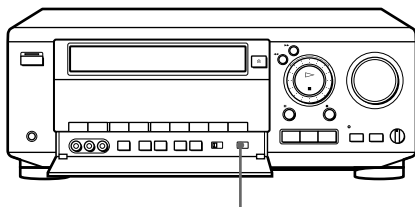
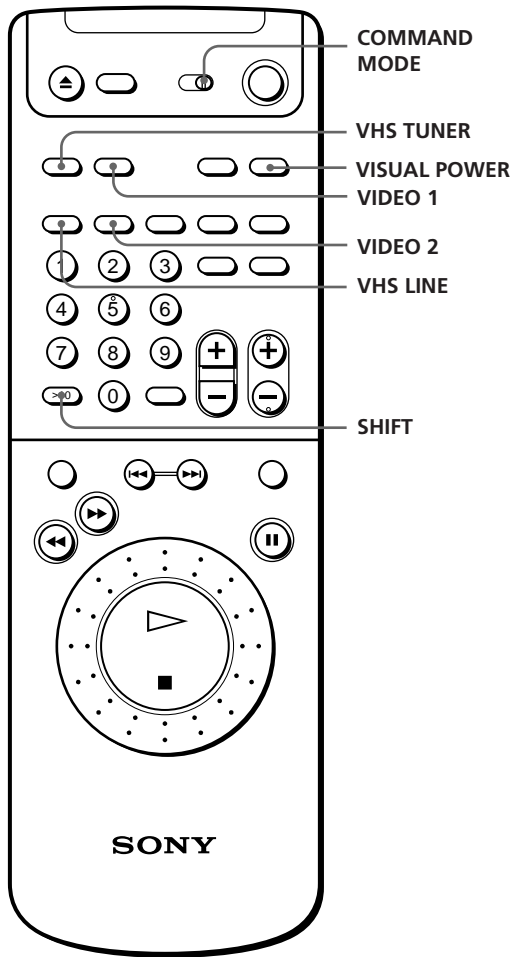

VTR COMMAND MODE OFF/1/2/3

## Controlling VCRs which have the COMMAND MODE selector

To control a VCR with the remote commander, set the COMMAND MODE selectors on the remote commander and the VCR to the same position. The COMMAND MODE\*<sup>1</sup> selectors on both the unit and remote commanders are factory set to VTR3. Be sure to set the COMMAND MODE selector on each VCR to a different position to operate each VCR independently.

If the COMMAND MODE selector on a VCR is set to OFF, you cannot control that VCR with the remote commander.

If the COMMAND MODE selector on this unit is set to OFF, although you cannot control the unit's VCR with the remote commander, MASTER VOL +/-, MUTING, and the function buttons on the remote commander can operate the unit.

\*<sup>1</sup> The selector's name on the unit is VTR COMMAND MODE, however, it is described as COMMAND MODE in these Operating Instructions for the sake of convenience.

## Controlling a VCR which doesn't have a COMMAND MODE selector

If a VCR has no COMMAND MODE selector, set COMMAND MODE on the remote commander in the following way.

If your VCR is a	Set COMMAND MODE to
Sony Betamax format VCR	VTR1
Sony 8mm format VCR	VTR2
Sony VHS format VCR	VTR3

If you have another VHS format VCR, set COMMAND MODE on the unit to VTR1 or VTR2.

## Turning on and controlling the unit's VCR

- 1 Set COMMAND MODE on the remote commander to the same position as COMMAND MODE on the unit.
- 2 Press VHS TUNER.
  - If the TV doesn't turn on or the LINE 1 is not selected on the TV, turn it on manually.
  - If connected with only the antenna cable, set the TV to the video channel.

## Turning on and controlling another VCR

- 1 Set COMMAND MODE on the remote commander to the same position as COMMAND MODE on the other VCR.  
If the other VCR doesn't have a COMMAND MODE selector, set COMMAND MODE on the remote commander according to the table in "Controlling a VCR which has no COMMAND MODE selector" on the previous page.
- 2 Press VIDEO1, VIDEO2, or VHS LINE depending on which jacks the other VCR is connected to.  
The other VCR and TV turn on, and the corresponding input source is selected.

## Customizing the remote commander to make controlling other VCRs easier

Initially VIDEO1 and VIDEO2 only select the input source, and COMMAND MODE on the remote commander determines which VCR you can control with the remote commander.

However, you can customize VIDEO1 and VIDEO2 on the remote commander to control the other VCR.

While pressing either VIDEO1 or VIDEO2,

- press number button 7 to control the VCR with its COMMAND MODE selector set to VTR1, or Betamax format VCR;
- press number button 8 to control the VCR with its COMMAND MODE selector set to VTR2, or 8mm format VCR; or,
- press number button 9 to control the VCR with its COMMAND MODE selector set to VTR3, or VHS format VCR.

The customized button is no longer related to the COMMAND MODE position. To turn on and control the other VCR with the remote commander, simply press the customized VIDEO1 or VIDEO2 button.

### To relate VIDEO1 or VIDEO2 with COMMAND MODE again

While pressing VIDEO1 or VIDEO2, press SHIFT.

## Using the remote commander buttons to control the other VCR

You can control the other VCR with the same buttons you use to control this unit's VCR. Note that the VCR Plus+, DISPLAY, MENU, CURSOR , TIMER REC ON/OFF, and TIMER CLEAR buttons, and the CLICK SHUTTLE ring don't operate other VCRs.

## Turning off the selected VCR

Press VISUAL POWER while the remote commander is in the selected VCR operation mode.

### Note

- You cannot do this customizing for VHS TUNER or VHS LINE. These buttons are always related to the COMMAND MODE position.

# Controlling the TV

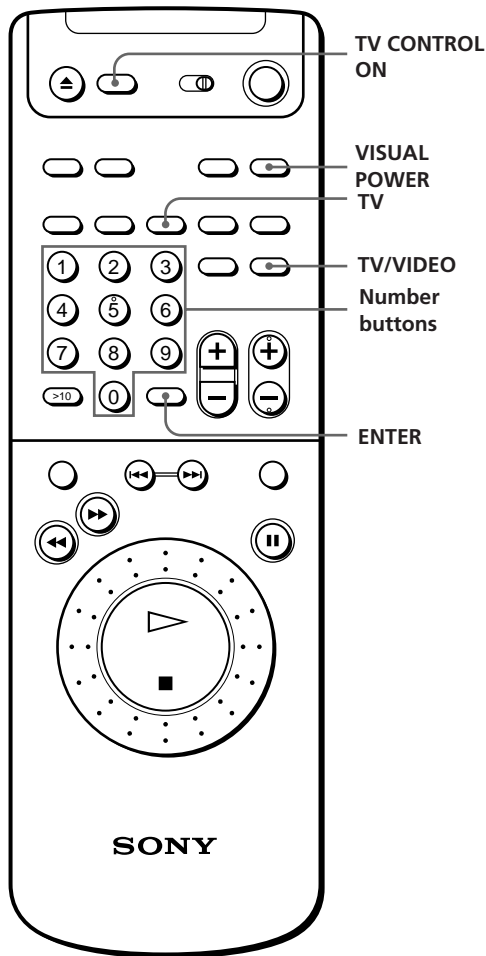

## Watching a TV program

- 1 Press TV.  
The TV and unit turn on.
- 2 Press the number buttons to select the channel and press ENTER.  
To scan through channel, lift the top cover of the remote commander, then press CH +/-.

## Selecting a stereo or bilingual program

Press AUDIO MONITOR. Each press changes the sound between bilingual and stereo.

## Using the WIDE function

Press TV WIDE. Each press changes the WIDE mode.

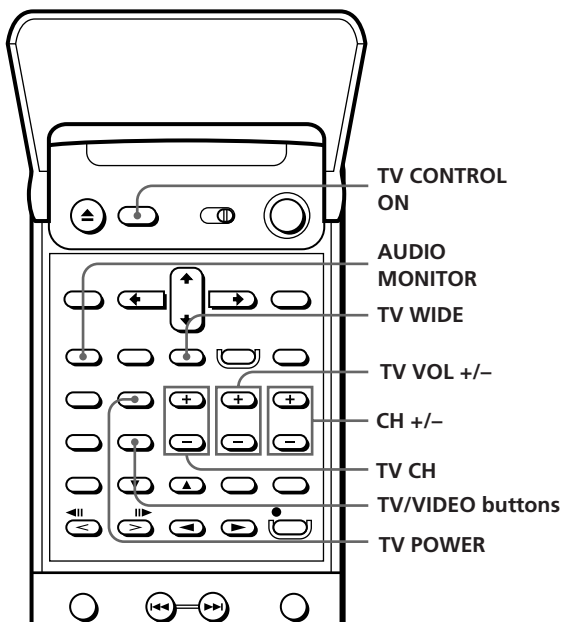

### Note

- You cannot use the on-screen display while the unit is in TV control mode.



## Controlling other TVs with the remote commander

The remote commander is preprogrammed to control non-Sony TVs. If your TV is listed in the table below, set the appropriate manufacturer's code number.

Hold down TV CONTROL ON, and enter your TV's code number(s) using the number buttons. Then release TV CONTROL ON.

Now you can use the TV POWER, TV VOL +/-, TV CH +/- and TV/VIDEO buttons to control your TV.

### Code numbers of controllable TVs

If more than one code number is listed, try entering them one at a time until you find the one that works with your TV.

Manufacturer	Code number	Manufacturer	Code number	Manufacturer	Code number
Sony	01	KMC	03	RCA	04,10
Akai	04	Magnavox	03,08,12	Sampo	12
AOC	04	Marantz	04,13	Sanyo	11
Centurion	12	MGA/Mitsubishi	04,12,13,17	Scott	12
Coronado	03	NEC	04,12	Sears	07,10,11
Curis-Mathes	12	Panasonic	06,19	Sharp	03,05,18
Daytron	12	Philco	03,04	Sylvania	08,12
Fisher	11	Philips	08	Teknika	03,08,14
General Electric	06,10	Pioneer	16	Toshiba	07
Hitachi	02,03	Portland	03	Wards	03,04,12
J.C.Penny	04,12	Quasar	06,18	Yorx	12
JVC	09	Radio Shack	05,14	Zenith	15

### Notes

- If the TV uses a different remote control system from the one programmed to work with the VCR, you cannot control your TV with the remote commander.
- If you enter a new code number, the code number previously entered will be erased.
- When you replace the batteries of the remote commander, the code number automatically resets to 1 (Sony). Reset the appropriate code number.

# Playing back a CD

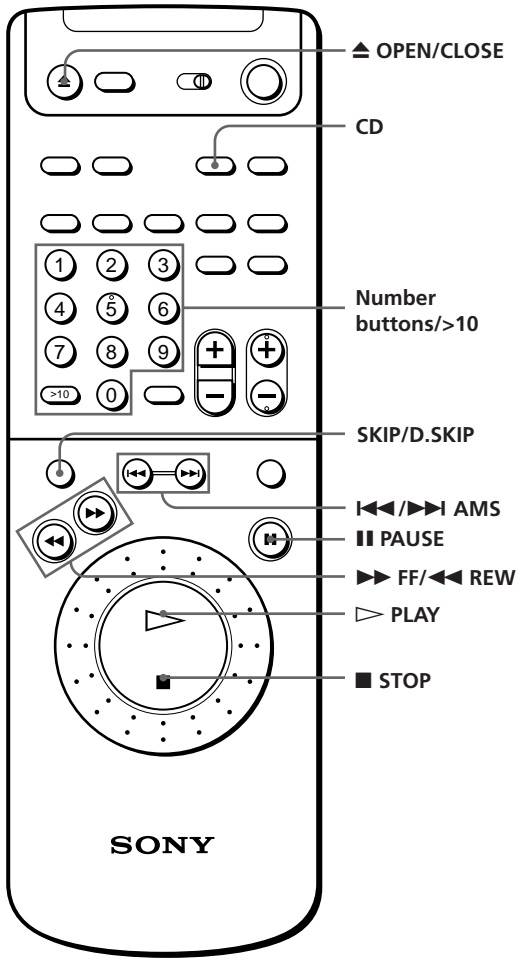

- 1 Press CD and turn on the CD player.  
The unit turns on and switches the input source to the CD player connected to the CD jacks.
- 2 Press ▲ OPEN/CLOSE to open the disc tray.  
If the disc tray or cover doesn't open, refer to your CD player's operating instructions.
- 3 Load a CD or CDs referring to your CD player's operating instructions.
- 4 Press ▲ OPEN/CLOSE to close the disc tray.  
If the disc tray or cover doesn't close, refer to your CD player's operating instructions.  
Depending on the CD player, you can skip this step. Refer to your CD player's operating instructions.
- 5 Press ▷ PLAY.  
Depending on the CD player, you can skip this step. Refer to your CD player's operating instructions.

## Additional tasks

To	Press
Stop play	■ STOP
Pause play	PAUSE
Resume play after pause	PAUSE or ▷ PLAY
Scan forward or backward	And hold ▶▶ FF or ◀◀ REW during playback
Locate the beginning of other tracks	◀◀ / ▶▶ AMS repeatedly
(Stop and) remove the CD This function doesn't operate some CD players.	▲ OPEN/CLOSE
Close the tray This function doesn't operate some CD players.	▲ OPEN/CLOSE
Select other discs This function only works for CD players with a built-in multi-disc changer.	SKIP/D.SKIP repeatedly during playback or before playback

## To locate a track with the number buttons

Press one of the number buttons for single digit track numbers (except 0).

To locate the 10th track, press 1, then 0.

To enter a track number over 10, first press >10, then any number button for the tens digit except 0, and the number button for the ones digit.

## Examples of entering the two-digit number

To	Press
Enter 30	>10, then 3, and 0
Enter 24	>10, then 2, and 4

## Controlling a cassette deck

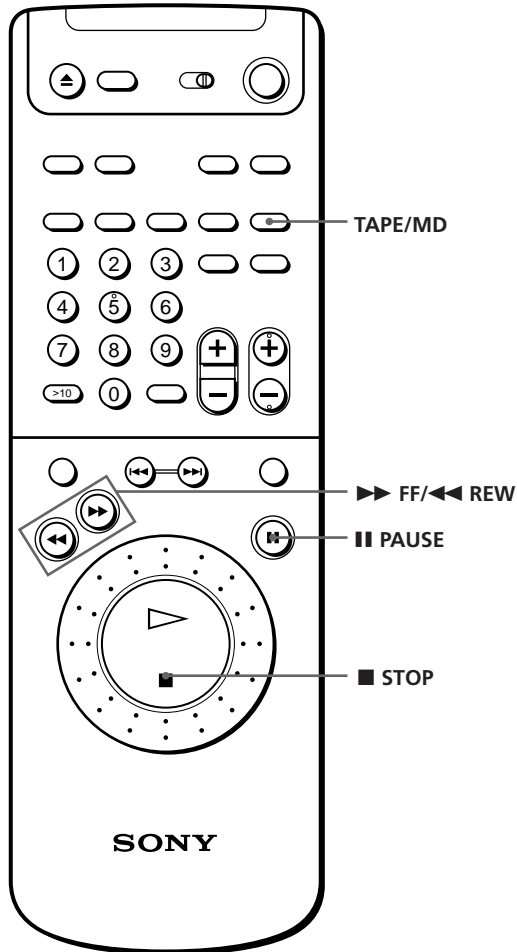

The remote commander's TAPE/MD button is factory set to work for single-cassette decks or deck B if you have a double-cassette deck. If you want the remote commander operate deck A, you need to customize your remote commander. See "Customizing the remote commander for deck A of a double-cassette deck" on the next page.

### Playing a tape

- 1 Press TAPE/MD, and turn on the cassette deck.  
The unit turns on and switches the input source to the cassette deck connected to the TAPE/MD jacks.
- 2 Insert a recorded cassette (into deck B for double-cassette decks) referring to your cassette deck's operating instructions.
- 3 Lift the top cover of the remote commander and press **▶ DIRECTION**.  
For reverse side playback, lift the top cover of the remote commander and press **◀ DIRECTION**.

### Additional tasks

To	Press
Stop play	■ STOP
Pause play	PAUSE
This function doesn't operate some cassette decks.	
Resume play after pause	▶ DIRECTION, ◀ DIRECTION, or    PAUSE
Fast-forward	▶▶ FF
Rewind	◀◀ REW

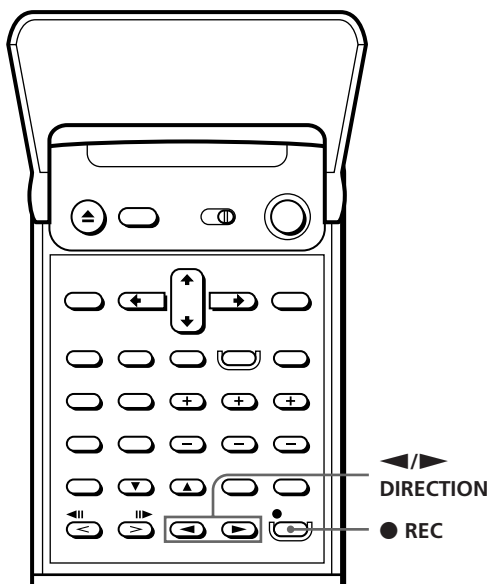

### Recording on a tape

- 1 Press TAPE/MD, and turn on the cassette deck.  
The unit turns on and switches the input source to the cassette deck connected to the TAPE/MD jacks.
- 2 Insert a blank cassette with its erasure prevention tabs in place (into deck B for a double-cassette deck) referring to your cassette deck's operating instructions.
- 3 Select the input source by pressing one of the function buttons on the unit.

If you want to select the unit's VCR or piece of equipment connected to the LINE jacks, press VHS repeatedly to display a channel or "LINE" on the TV screen.

If you want to select a piece of equipment connected to the VIDEO 1 or VIDEO 2 jacks, press VIDEO repeatedly to display "VIDEO 1" or "VIDEO 2" on the TV screen.

If you want to select the CD player or tuner, press AUDIO repeatedly to display "CD" or "TUNER" on the TV screen.

continued

## Controlling a cassette deck (continued)

- 4 Lift the top cover of the remote commander and press ● REC to set the cassette deck to recording pause.
- 5 Press ► DIRECTION (or ◀ DIRECTION to record on the reverse side).  
Recording starts.
- 6 Play back the program source.

### Additional tasks

To	Press
Stop recording	■ STOP
Pause recording	PAUSE
Resume recording	PAUSE, ► DIRECTION, or ◀ DIRECTION

## Customizing the remote commander for deck A of a double-cassette deck

The remote commander's TAPE/MD button is factory set to operate single-cassette decks or deck B if you have a double-cassette deck. To control deck A, first you need to customize one of the function buttons for deck A.

You can customize the VIDEO 1, VIDEO 2, CD, TAPE/MD, or TV function buttons. While pressing the selected function button, press the number button 5. (You must select the function button corresponding to the input jacks the cassette deck is connected to.)

Now that function button operates deck A. To change the button's function again, see "Customizing the remote commander function buttons" on page 91.

To play back a tape, follow the instructions in "Playing a tape" on the previous page. During the procedure, press the function button you customized for deck A in step 1 instead of TAPE/MD, and insert a recorded cassette into deck A in step 2 instead of deck B.

# Controlling a DAT deck

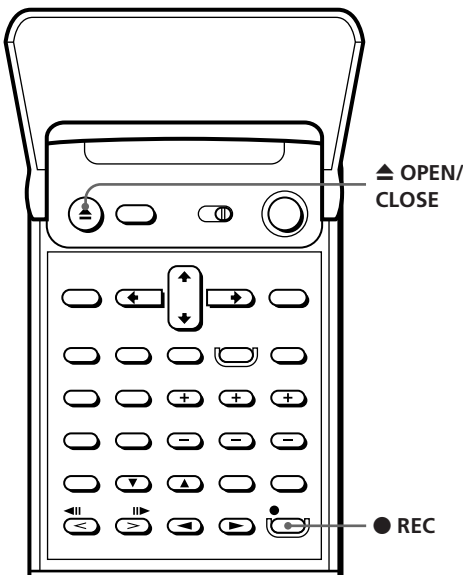
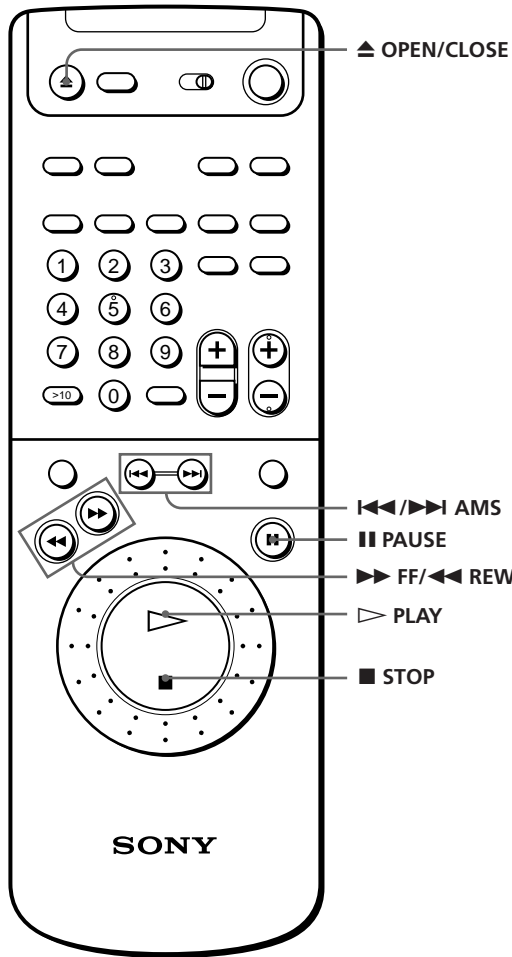

## Customizing the remote commander for a DAT deck

The remote commander is not factory set to control DAT decks. So you need to customize the function button corresponding to the jacks the DAT deck is connected to. For example, if you connect the DAT deck to the TAPE/MD jacks, customize TAPE/MD for the DAT deck in the following way.

While pressing the function button (e.g. TAPE/MD), press number button 2.

The function button is customized to control the DAT deck.

You can customize the VIDEO 1, VIDEO 2, CD, TAPE/MD, or TV function buttons. To change the button's function again, see "Customizing the remote commander function buttons" on page 91.

## Playing a tape

- 1 Press the function button you customized for the DAT deck, and turn on the DAT deck.  
The unit turns on and switches the input source to the jacks the DAT deck is connected to.
- 2 Press **▲ OPEN/CLOSE** to open the cassette cover /holder.  
If the cassette cover /holder doesn't open, refer to your DAT deck's operating instructions.
- 3 Insert a cassette.
- 4 Press **▷ PLAY**.  
The deck starts playing a tape.

## Additional tasks

To	Press
Stop playing	■ STOP
Go to the next track	▶▶ AMS
Go to the preceding track	◀◀ AMS
Fast-forward or rewind	▶▶ FF or ◀◀ REW during stop
Monitor the sound during fast-forward or rewind	▶▶ FF or ◀◀ REW during playback. To resume normal playback, release the button.
Eject the cassette	▲ OPEN/CLOSE during stop

continued

## Controlling a DAT deck (continued)

### Note

- You must connect the DAT deck to the TAPE/MD jacks to record on a tape with the DAT deck.

## Recording on a tape

- 1 Press the function button you customized for the DAT deck, and turn on the DAT deck.

The unit turns on and switches the input source to the TAPE/MD jacks the DAT deck is connected to.

- 2 Insert a cassette with the record-protect tab closed.
- 3 Select an input source by pressing one of the function buttons on the unit.

If you want to select the unit's VCR or piece of equipment connected the LINE jacks, press VHS repeatedly to display a program position or "LINE" on the TV screen.

If you want to select a piece of equipment connected to the VIDEO 1 or VIDEO 2 jacks, press VIDEO repeatedly to display "VIDEO 1" or "VIDEO 2" on the TV screen.

If you want to select the CD player or tuner, press AUDIO repeatedly to display "CD" or "TUNER" on the TV screen.

- 4 Locate the point you want to start recording from.  
To record from the beginning of the tape, press ◀◀ REW to rewind the tape to the beginning.

To record from the end of the recorded portion, press ▶▶ FF.

The deck locates the end of the recorded portion on the tape and stops automatically.

- 5 Lift the top cover of the remote commander and press ● REC to set the MD deck to recording pause.
- 6 Press ▷ PLAY or || PAUSE.  
Recording starts.
- 7 Play back the program source.

### Additional tasks

To	Press
Stop recording	■ STOP
Pause recording	PAUSE To resume recording, press the button again.
Resume recording	PAUSE or ▷ PLAY

# Controlling an MD deck

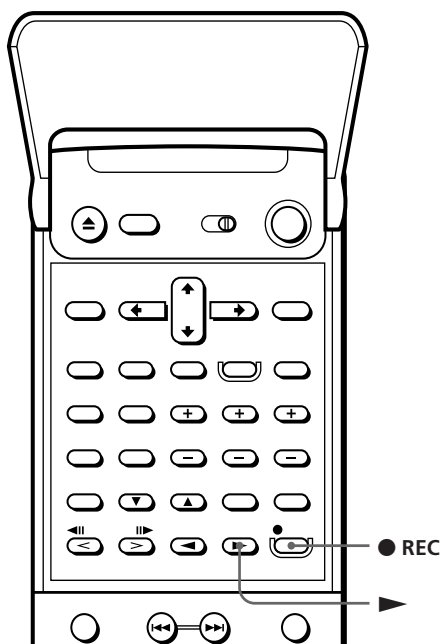
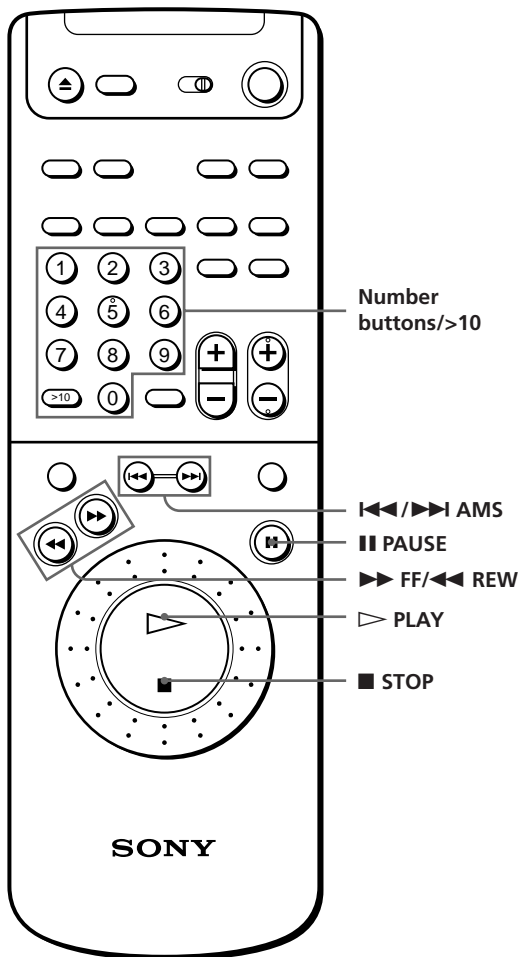

## Customizing the remote commander for an MD deck

The remote commander is not factory set to control MD decks. So you need to customize the function button corresponding to the jacks the MD deck is connected to. For example, if you connect the MD deck to the TAPE/MD jacks, customize TAPE/MD for the MD deck in the following way.

While pressing the function button (e.g. TAPE/MD), press number button 3.

The function button is customized to control the MD deck.

You can customize the VIDEO 1, VIDEO 2, CD, TAPE/MD, or TV function buttons. To change the button's function again, see "Customizing the remote commander function buttons" on page 91.

## Playing an MD

- 1 Press the function button you customized for the MD deck, and turn on the MD deck.  
The unit turns on and switches the input source to the jacks the MD deck is connected to.
- 2 Insert an MD referring to your MD deck's operating instructions.
- 3 Press ▷ PLAY.  
The MD deck starts playing.

### Additional tasks

To	Press
Stop play	■ STOP
Pause play	II PAUSE
Resume play after pause	II PAUSE or ▷ PLAY
Scan forward or backward	And hold ►► FF or ◀◀ REW during playback
Locate the beginning of other tracks	I<</>>I AMS repeatedly

### To locate a track with the number buttons

Press one of the number buttons for single digit numbers (except 0). To locate the 10th track, press 1, then 0.

To enter a track number over 10, first press >10, then any number button for the tens digit except 0, and the number button for the ones digit.

### Examples of entering the two-digit number

To	Press
Enter 30	>10, then 3, and 0
Enter 24	>10, then 2, and 4

continued

---

## Controlling an MD deck (continued)

### Note

- You must connect the MD deck to the TAPE/MD jacks to record on an MD with the MD deck.

## Recording on an MD

- 1** Press the function button you have customized for the MD deck, and turn on the MD deck.  
The unit turns on and switches the input source to the TAPE/MD jacks the MD deck is connected to.
- 2** Insert an MD with its erasure prevention tab closed, referring to your MD deck's operating instructions.
- 3** Select the input source by pressing one of the function buttons on the unit.  
If you want to select the unit's VCR or piece of equipment connected to the LINE jacks, press VHS repeatedly to display a program position or "LINE" on the TV screen.  
If you want to select a piece of equipment connected to the VIDEO 1 or VIDEO 2 jacks, press VIDEO repeatedly to display "VIDEO 1" or "VIDEO 2" on the TV screen.  
If you want to select the CD player or tuner, press AUDIO repeatedly to display "CD" or "TUNER" on the TV screen.
- 4** Lift the top cover of the remote commander and press ● REC to set the MD deck to recording pause.
- 5** Press ► (or ▷ PLAY)  
Recording starts.
- 6** Play back the program source.

### Additional tasks

To	Press
Stop recording	■ STOP
Pause recording	PAUSE. Press the button again to resume recording.
Resume recording	PAUSE or ▷ PLAY



# Controlling an LD player

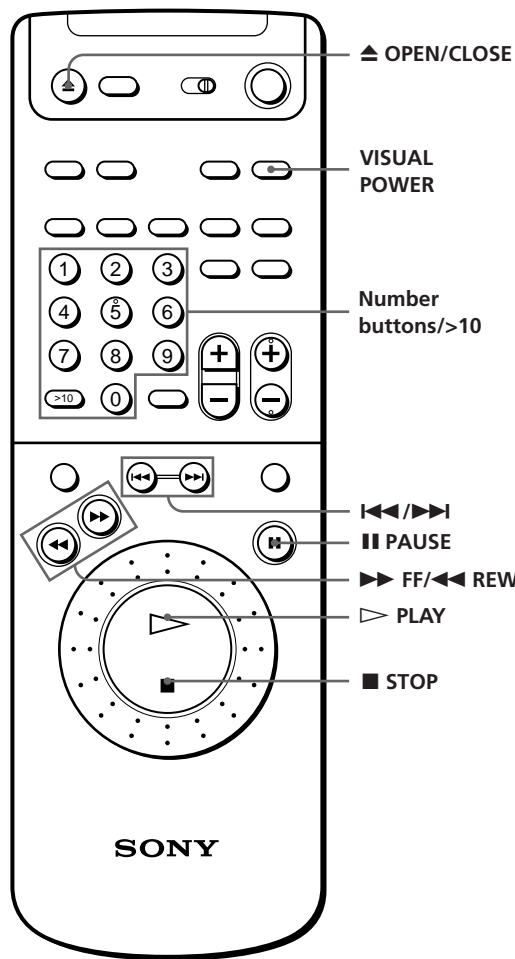

## Customizing the remote commander for an LD player

The remote commander is not factory set to control LD players. So you need to customize the function button corresponding to the jacks the LD player is connected to. For example, if you connect the LD player to the VIDEO 1 jacks, customize VIDEO1 for the LD player in the following way.

While pressing the function button (e.g. VIDEO1), press number button 6.

The function button is customized to control the LD player.

You can customize the VIDEO 1, VIDEO 2, CD, TAPE/MD, or TV function buttons. To change the button's function again, see "Customizing the remote commander function buttons" on page 91.

## Playing back an LD

- 1 Press the function button you customized for the LD player, and turn on the LD player.

The unit turns on and switches the input source to the jacks the LD player is connected to.

- 2 Press ▲ OPEN/CLOSE to open the disc tray.
- 3 Place an LD on the disc tray.
- 4 Press ▷ PLAY.

The disc tray closes and side A of the LD starts playing.

When playback of side A ends, side B starts playing automatically.

### Additional tasks

To	Press
Stop play	■ STOP
Pause play	PAUSE
Resume play after pause	PAUSE or ▷ PLAY
Scan forward or backward	And hold ►► FF or ◀◀ REW during playback
Skip chapters or tracks	◀◀ / ►► repeatedly
(Stop and) remove the LD	▲ OPEN/CLOSE
Close the tray	▲ OPEN/CLOSE

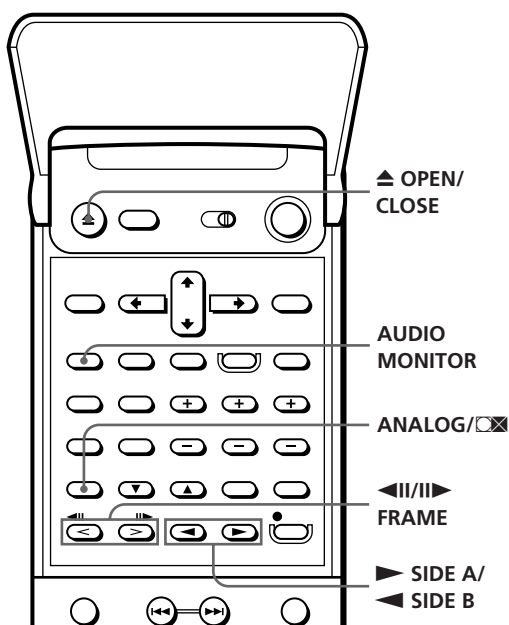

### To start playback from the beginning of either LD side

Press ► SIDE A to play side A of the LD from the beginning.

Press ◀ SIDE B to play side B of the LD from the beginning.

### To pause playing just before starting

Press || PAUSE instead of ▷ PLAY after you place an LD on the disc tray.

The disc tray closes and the player waits at the start of the LD until you press ▷ PLAY or || PAUSE. If you want to start from side B, press

◀ SIDE B after you press || PAUSE.

continued

## Controlling an LD player (continued)

### To locate a particular chapter or track

Press any number button to enter the single digit chapter/track number (except 0).

For two-digit numbers, press >10 repeatedly to enter the tens digit (the number of times you press the button becomes the tens digit number). Then press any number button to enter the ones digit.

### Examples of entering a two-digit number

To	Press
Enter 30	>10 three times, then press 0
Enter 14	>10 once, then press 4

To play a chapter or track on the opposite side of the LD, press ◀ SIDE B while playing SIDE A (or ▶ SIDE A while playing SIDE B), then enter the chapter or track number.

### To play frame-by-frame (Step Play)

Press ◀||/||▶ FRAME repeatedly. Each press shifts the picture to the next frame.

For continuous frame playback, press and hold ◀||/||▶ FRAME.

To resume normal playback, press ▷ PLAY.

### To listen to analog sound from an LD

If your LD contains digital sound tracks, the player automatically outputs digital sound. To listen to the sound recorded on analog soundtracks, press ANALOG/◻. To resume the digital mode, press ANALOG/◻ again.

### To play a stereo disc or Second Audio Programme (SAP) disc

When playing SAP discs such as bilingual discs, you can alternate the sound output by pressing AUDIO MONITOR. Each press changes the sound as follows.

Stereo disc	SAP disc
Left channel	Sound track 1 (Left channel)
Right channel	Sound track 2 (Right channel)
Stereo (Both channels)	Both tracks (Left and right channels)

### To play an LD with the ◻ (CX) logo

LDs with the ◻ logo are recorded with the CX noise reduction system for analog sound. Although LD players usually detect and activate this system, you can manually set the LD player to use the system.

Press ANALOG/◻.

To cancel this function, press ANALOG/◻ again.

### Turning off the LD player

Press VISUAL POWER while the remote commander is in LD control mode.

## Sound Field Operations

# Taking advantage of the sound fields

You can enjoy the surround sound effect by simply selecting one of the pre-programmed sound fields according to the type of playback source.

- 1 Select the input source.
- 2 Select the sound field. (See “Using the pre-programmed sound fields” on page 49.)

You can set the sound effect independently for each input source.

### Selecting the sound field

Select	To	You need the following speakers
PROLOGIC	Fully enjoy programs processed with Dolby Pro Logic Surround sound (See “What’s Dolby Surround and Dolby Pro Logic Surround?” on the next page.)	See “Selecting the center mode” on page 32.
THEATER	Add the acoustic reflections of a theater to the decoded Dolby Surround signals (See “What’s Dolby Surround and Dolby Pro Logic Surround?” on the next page.)	See “Selecting the center mode” on page 32.
MONO MOVIE	Create a theater-like environment for movies with monaural soundtracks (See “What’s surround sound?” on the next page.)	The surround (rear left and right) speakers as well as the front left and right speakers
HALL	Reproduce the acoustics of a hall (See “What’s surround sound?” on the next page.)	The surround (rear left and right) speakers as well as the front left and right speakers
STADIUM	Reproduce the feeling of a large open-air stadium (See “What’s surround sound?” on the next page.)	The surround (rear left and right) speakers as well as the front left and right speakers
GAME	Obtain maximum audio impact from video game software (See “What’s surround sound?” on the next page.)	The surround (rear left and right) speakers as well as the front left and right speakers
ACOUSTIC	Reproduce normal 2 channel stereo	Only the front left and right speakers
OFF	Turn off the sound effect	Only the front left and right speakers

#### To temporarily turn off the sound effect you set

- 1 Select the input source for the sound effect you want to turn off.
- 2 Press SURROUND on the unit to turn off the sound effect.

To resume the previous sound effect, press SURROUND again.

continued

## Taking advantage of the sound fields (continued)

### What's Dolby Surround and Dolby Pro Logic Surround?

Dolby Surround is a system that decodes the extra channels of Dolby Surround encoded sound tracks on movie videos and TV programs, and produces sound effects and echoes that make the action seem to envelop you.

Dolby Pro Logic Surround is a more advanced system developed after Dolby Surround. The sound image is improved by using four separate channels: off-screen audio effects, on-screen dialogue, left-to-right panning, and music. These channels manipulate the sound and enhance the action as it happens on the screen.

The unit offers PROLOGIC mode for these systems as one of the sound fields. You can tell if a video tape or laser disc uses Dolby Surround or Dolby Pro Logic Surround encoded software by looking at the packaging. (Some video tapes and laser discs may use Dolby Surround even if it's not indicated on the package.)

### What's surround sound?

Surround sound consists of three elements, direct sound, early reflected sound (early reflections), and reverberated sound (reverberation). The acoustics of the venue affect the way these three sound elements are heard.

The unit combines the three sound elements in such a way that you can actually feel the size and type of a particular venue such as a concert hall. The unit also varies the combination of the sound elements to offer you a variety of sound fields (THEATER, MONO MOVIE, HALL, STADIUM, and GAME).

### The three sound elements in an actual concert hall

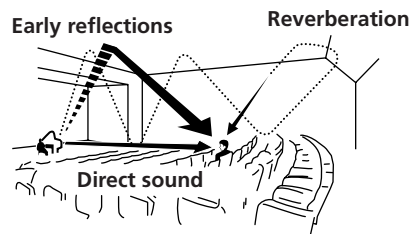

### Transition of sound from rear speakers

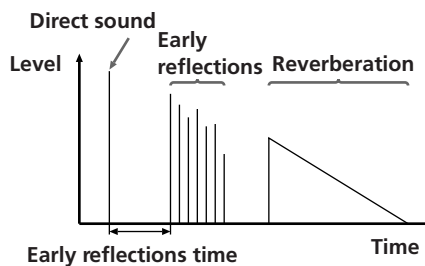

# Getting the most out of Dolby Pro Logic Surround sound

To obtain the best possible Dolby Pro Logic Surround sound, you need to adjust the delay time. The center mode and speaker levels were set in EASY SET UP, so you don't have to change those settings unless you change the speaker configuration.

If you change the speaker configuration, see "Reconfiguring the PROLOGIC and THEATER sound fields" on page 82.

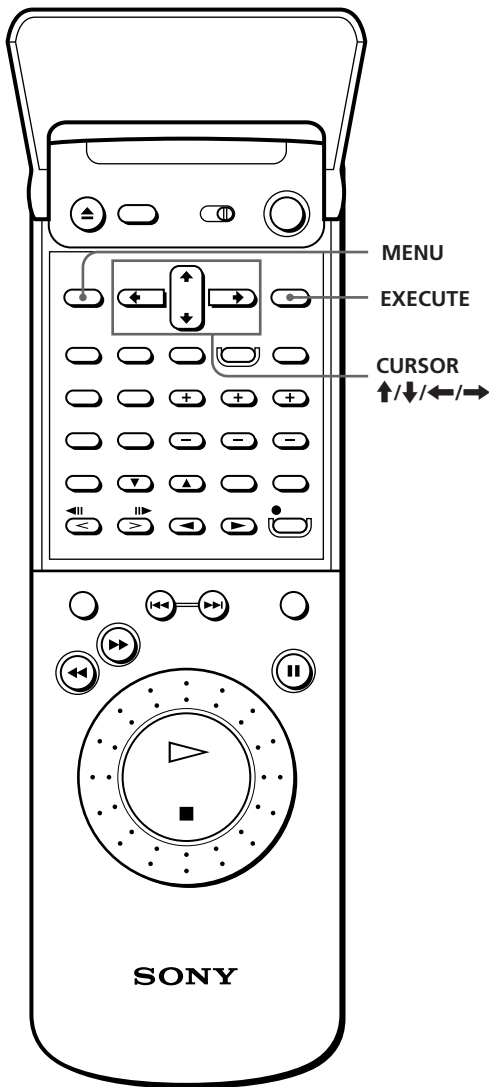

## Adjusting the delay time

You can make the surround sound more effective by delaying the output from the rear speakers (delay time) relative to the front speakers. You don't have to adjust the delay time if you select 3CH LOGIC for CENTER MODE.

- 1 Repeat steps 1 through 4 in "Using the pre-programmed sound fields" on page 49 and select PROLOGIC in step 3.**

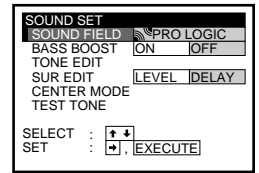

- 2 Press CURSOR ↑/↓/←/→ to move the cursor (I) to SUR EDIT, then highlight DELAY.**

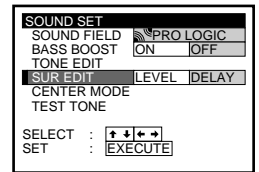

- 3 Press EXECUTE, then press CURSOR ←/→ to select 15ms, 20ms, 25ms, or 30ms as the delay time.**

Make the delay time longer when you have placed the rear speakers in a small room or close to your listening position, and make it shorter when you have placed them in a large room or far from your listening position.

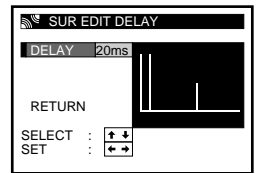

- 4 Press MENU to return to the original screen.**

# Customizing the sound fields

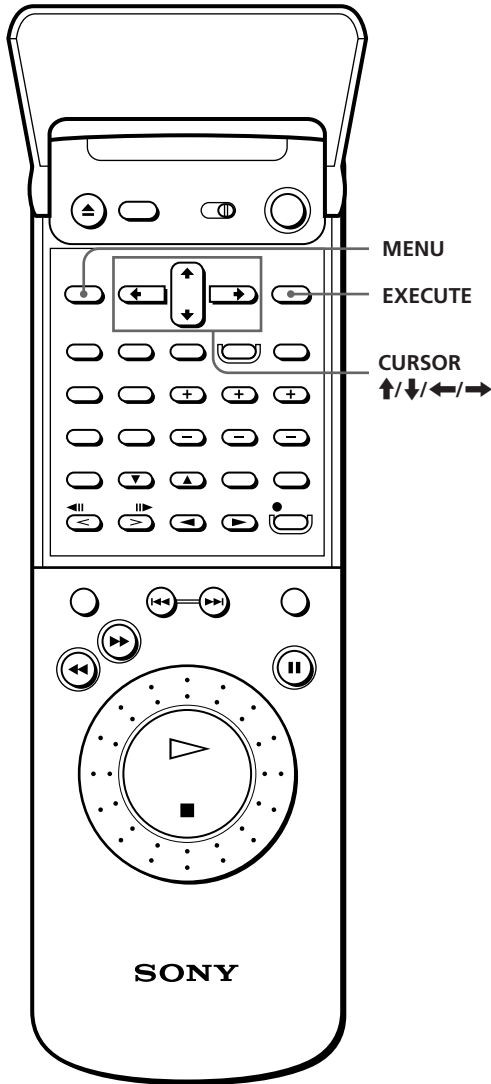

Each sound field is composed of an equalizer (bass, midrange, and treble) and surround sound parameters: sound variables that create the sound image. You can customize the sound fields by adjusting the speaker levels, effects, and surround sound parameters to suit your listening situation.

Once you customize the sound fields, they are stored in memory.

## Adjusting the speaker level for THEATER, MONO MOVIE, HALL, STADIUM, or GAME

**1** Start playing a program source, then repeat steps 1 through 4 in “Using the pre-programed sound fields” on page 49 and select one of the above sound fields in step 3.

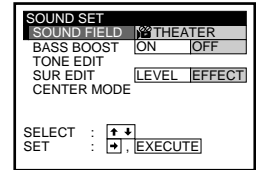

**2** Press CURSOR  $\uparrow/\downarrow/\leftarrow/\rightarrow$  to move the cursor (I) to SUR EDIT, then highlight LEVEL.

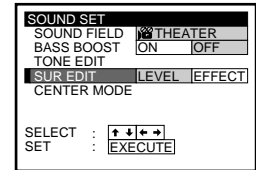

**3** Press EXECUTE. Then, press CURSOR  $\uparrow/\downarrow$  to move the cursor to CENTER, and press CURSOR  $\leftarrow/\rightarrow$  to increase or decrease the volume of the center speaker to a preferable level.

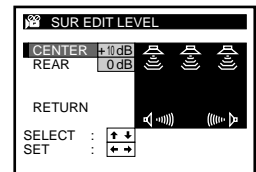

If you select MONO MOVIE, HALL, STADIUM, or GAME in step 1, skip this step.

If you select THEATER in step 1, and you set the center mode to PHANTOM (see “Selecting the center mode” on page 32), skip this step.

**4** Press CURSOR  $\uparrow/\downarrow$  to move the cursor (I) to REAR, then press CURSOR  $\leftarrow/\rightarrow$  to increase or decrease the volume of the rear speakers to a preferable level.

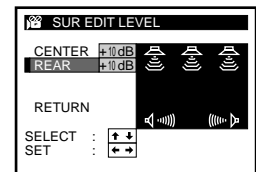

If you select THEATER in step 1 and 3CH LOGIC is selected as the center mode (see “Selecting the center mode” on page 32), skip this step.

The rear speakers’ volume balance is always even.

**5** Press MENU to return to the original screen.

### Tips

- To adjust the relative volume balance between the front left and right speakers, use BALANCE L/R on the unit.
- To restore the factory settings of the sound fields, turn on the unit while pressing SURROUND.

### To return to the previous menu

Select RETURN instead of pressing MENU in step 5, then press EXECUTE.

## Adjusting the tone for all sound fields

Adjust the tone of the front, center and rear speakers for optimum sound. You can adjust the tone for all sounds fields, including PROLOGIC.

- 1 Start playing a program source, then repeat steps 1 through 4 in "Using the pre-programmed sound fields" on page 49 and select one of the sound fields in step 3.**

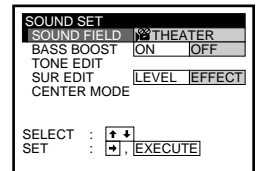

- 2 Press CURSOR ↑/↓ to move the cursor (I) to TONE EDIT.**

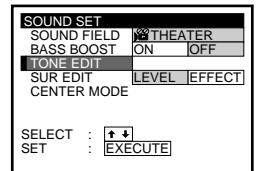

- 3 Press EXECUTE. Then, press CURSOR ↑/↓ to move the cursor (I) to BASS, and press CURSOR ←/→ to adjust the level of the low frequencies as you like.**

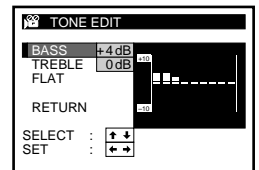

- 4 Press CURSOR ↑/↓ to move the cursor (I) to TREBLE, then press CURSOR ←/→ to adjust the level of the high frequencies as you like.**

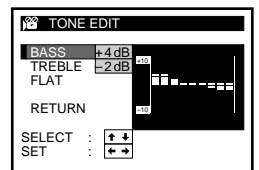

- 5 Press MENU to return to the original screen.**

### To return to the previous menu

Select RETURN instead of pressing MENU in step 5, then press EXECUTE.

### To start your adjustment from a flat equalizer curve

Select FLAT after pressing EXECUTE in step 3 above, then adjust BASS and TREBLE.

#### Note

- When SF OFF is selected, the tone cannot be adjusted.

continued

## Adjusting the effect level for THEATER, MONO MOVIE, HALL, STADIUM, or GAME

You can adjust the influence of the sound field to the level you like.

- 1 Start playing a program source, then repeat steps 1 through 4 in “Using the pre-programmed sound fields” on page 49 and select one of the above sound fields in step 3.**

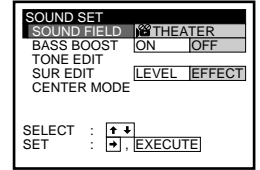

- 2 Press CURSOR  $\uparrow/\downarrow/\leftarrow/\rightarrow$  to move the cursor (I) to SUR EDIT, then highlight EFFECT.**

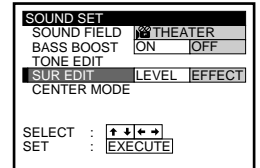

- 3 Press EXECUTE, then press CURSOR  $\uparrow/\downarrow$  to select 1, 2, 3, or 4 as the effect level.**

If you select THEATER in step 1, and you set the center mode to PHANTOM (see “Selecting the center mode” on page 32), skip this step.

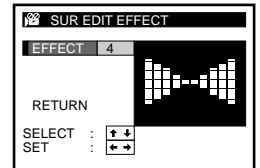

- 4 Press MENU to return to the original screen.**

### To return to the previous menu

Select RETURN in stead of pressing MENU in step 4, then press EXECUTE.



## Reinforcing the bass sound for all sound fields

In addition to the other sound effects, you can reinforce the bass sound for all sounds fields including PROLOGIC.

- 1** Start playing a program source, then repeat steps 1 through 4 in "Using the pre-programed sound fields" on page 49 and select one of the sound fields in step 3.

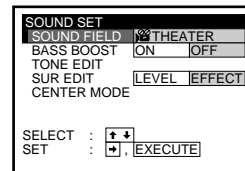

- 2** Press CURSOR  $\uparrow/\downarrow/\leftarrow/\rightarrow$  to move the cursor (I) to BASS BOOST, then highlight ON.

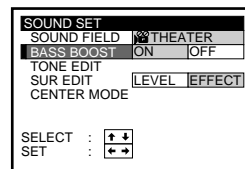

- 3** Press MENU to return to the original screen.

# Reconfiguring the PROLOGIC and THEATER sound fields

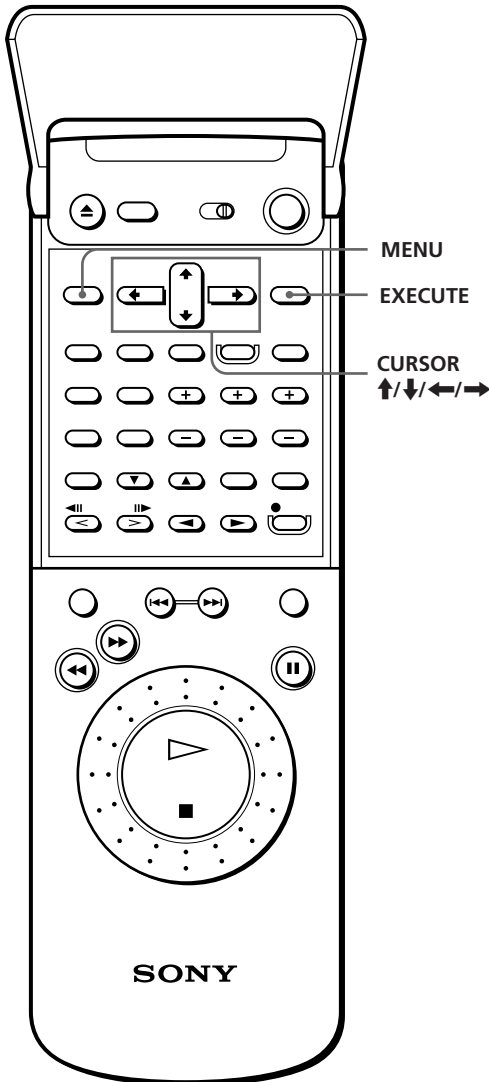

## Tip

- To adjust the relative volume balance between the front left and right speakers, use BALANCE L/R on the unit.

If you change your speaker configuration, you need to readjust the center mode and speaker levels for the PROLOGIC and THEATER sound fields.

- Repeat steps 1 through 4 in "Using the pre-programed sound fields" on page 49 and select PROLOGIC or THEATRE in step 3.

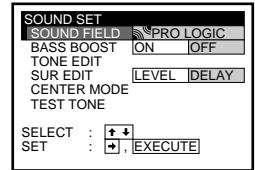

- Press CURSOR  $\uparrow/\downarrow$  to move the cursor (I) to CENTER MODE, then press EXECUTE.

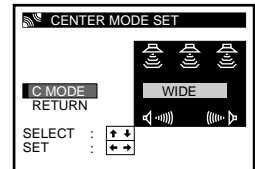

- Press CURSOR  $\leftarrow/\rightarrow$  to select the center mode, then press CURSOR  $\downarrow$  to highlight RETURN.

See "Selecting the center mode" on page 32.

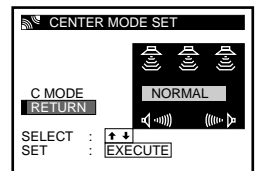

- Press EXECUTE, then press CURSOR  $\uparrow/\downarrow$  to highlight TEST TONE.

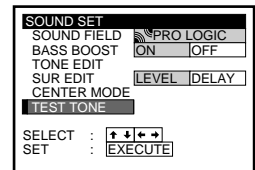

- Press EXECUTE.

Each speaker emits the test tone in turn (the speaker emitting the test tone is indicated by the red speaker mark).

Check each speaker's relative volume balance with the test tones.

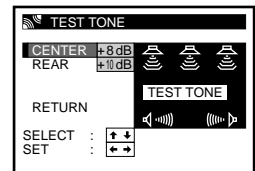

- Press CURSOR  $\leftarrow/\rightarrow$  to increase or decrease the volume of the center speaker.

If you selected PHANTOM in step 3, skip this step.

For PROLOGIC sound, you should have an equal volume balance with the other speakers at your listening position.

For THEATER sound, you can adjust the speaker level as you like.

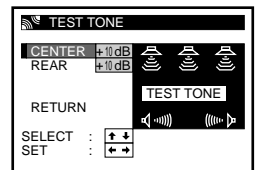

- 
- 7** Press **CURSOR** **↑/↓** to move the cursor (**I**) to **REAR**, then press **CURSOR** **←/→** to increase or decrease the volume of the rear speakers.

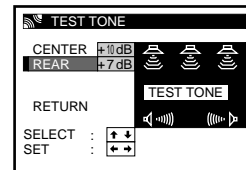

If you selected 3CH LOGIC in step 3, skip this step.

For PROLOGIC sound, you should have an equal volume balance with the other speakers at your listening position.

For THEATER sound, you can adjust the speaker level as you like.

The surround speakers' volume balance is always even.

- 
- 8** Press **MENU** to return to the original screen.
- 

### **Adjusting the speaker level by listening to the program source**

- 1 Start playing a program source, then repeat step 1 through 4 in "Using the pre-programmed sound fields" on page 49 and select PROLOGIC or THEATER in step 3.
- 2 Press **CURSOR** **↑/↓/←/→** to move the cursor (**I**) to **SUR EDIT**, then highlight **LEVEL**.
- 3 Repeat steps 5 through 8 on the previous page.

### **Increasing the maximum rear speaker level**

Although the adjustment range of the rear speakers is preset from -15 to +10 dB, you can shift the range up 5 dB (-10 to +15 dB). Hold down **MUTING** on the unit while turning on the power. "GAIN UP" appears in the display window.

The values for the rear level remain fixed at -15 to +10 dB on the menu, but you will be able to hear the difference in the actual output level.

To reset the rear level adjustment range, repeat this procedure so "GAIN NOR" appears in the display window.

# Advanced VCR Operations

## Playing/searching at various speeds

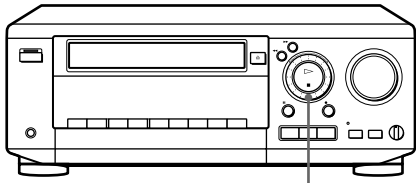

Shuttle ring

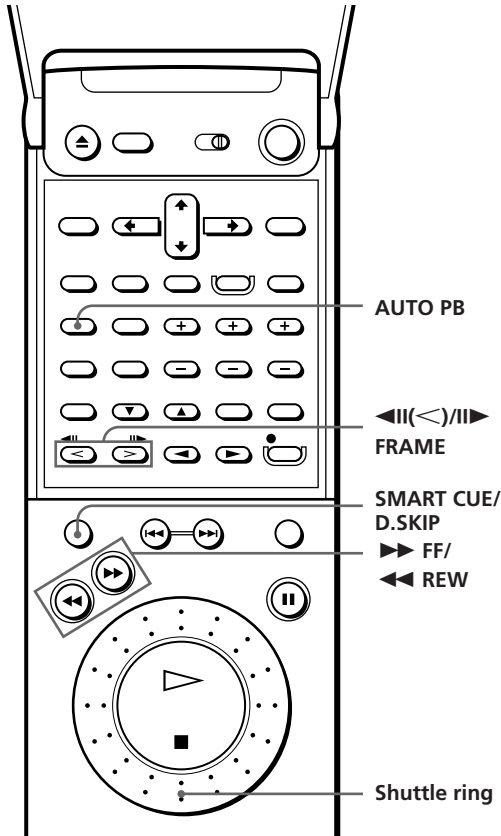

Playback options	Operation
View the picture during fast-forward or rewind	During fast-forward, press and hold <b>▶▶ FF</b> . During rewind, press and hold <b>◀◀ REW</b> .
Play frame by frame	During pause, lift the top cover of the remote commander and press <b>  ▶ FRAME</b> or <b>◀   FRAME</b> . Hold down either button to play one frame each second.
Play in reverse	During playback, press <b>&lt;</b> .
Rewind and start play	During stop, lift the top cover of the remote commander and press <b>AUTO PB</b> .

### Using the Shuttle ring

With the Shuttle ring, you can operate a variety of playback options. During playback or pause, turn the Shuttle ring clockwise or anticlockwise. Each change in the Shuttle ring position changes the playback mode, and the corresponding mark appears on the TV screen for a few seconds in the following way if the on-screen display function is on:

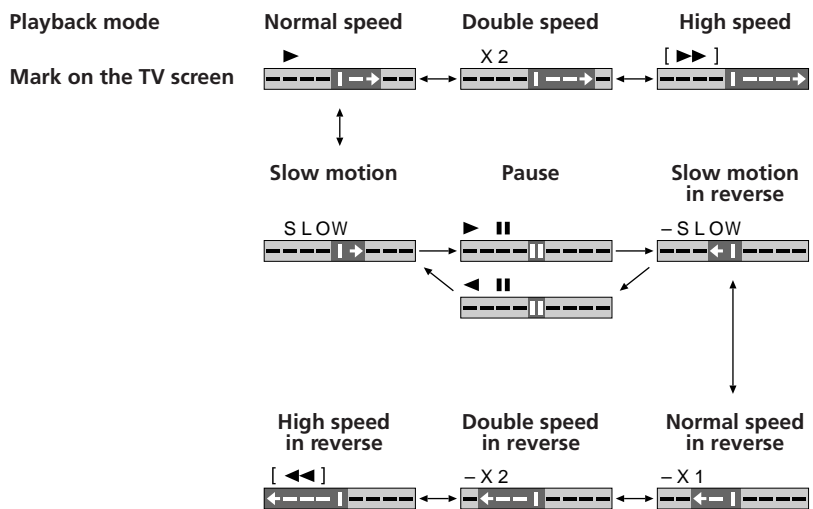

#### Tip

- Adjust the picture using **▼/▲** STILL ADJUST if:
  - Streaks appear while playing in slow motion.
  - Bands appear at the top or bottom while pausing.
  - The picture shakes while pausing.

#### Notes

- The playback sound is muted during these modes except for normal speed playback.
- Tapes recorded in the LP mode on other VCRs can be played back on this unit's VCR but the picture quality cannot be guaranteed.
- If the playback mode doesn't appear on the TV screen, press **DISPLAY**.

## Recording TV programs using the quick timer

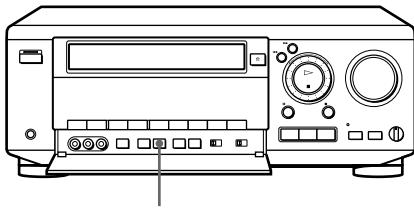

QUICK TIMER

### Tips

- You can also set the quick timer and start recording during stop mode. In this case, the unit must be turned on before you start recording.
- You can turn off the unit while recording with the quick timer. This doesn't affect the quick timer recording.
- You can enjoy watching or listening to another input source even during quick timer recording.

### Note

- You can use the quick timer only for recording TV programs from the unit's VCR tuner or LINE input source.

After you start recording a TV program from the unit's VCR tuner, or a DSS receiver connected to the LINE jacks in the normal way, you can have the unit's VCR stop recording automatically after a specified duration.

- 1 While recording, press QUICK TIMER once.

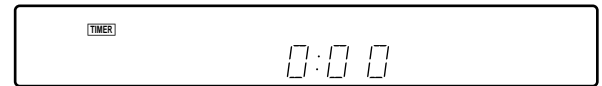

- 2 Press QUICK TIMER repeatedly to set the duration. Each press advances the time in 30 minute increments.

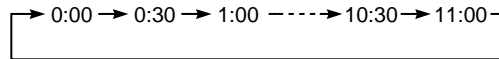

The duration decreases minute by minute to 0:00, then the unit's VCR stops recording and turns off automatically.

### To extend the duration

Press QUICK TIMER repeatedly to set to the new duration.

### To stop recording

To stop the unit's VCR while recording, press TIMER REC ON/OFF.

# Recording stereo and bilingual programs

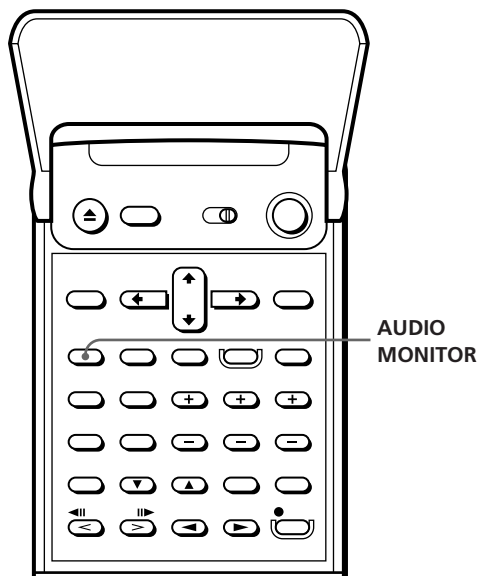

### Notes

- If the AUDIO MONITOR button does not function, check that AUDIO MIX in the SET UP MENU is set to OFF.
- When you play a tape recorded in monaural, the sound is heard in monaural regardless of the AUDIO MONITOR setting.

## Recording stereo programs

This VCR automatically receives and records stereo programs. When a stereo program is received, the STEREO indicator lights up. If there is noise in the stereo program, set AUTO STEREO in the ADVANCED OPTIONS menu to OFF. The sound will be recorded in monaural (on both hi-fi and normal audio tracks) but with less noise. For details, see page 89.

## Recording bilingual programs

Normally, this VCR records only the main sound on both hi-fi and normal audio tracks. To record SAP (Second Audio Program) sound on the normal audio track, set NORMAL AUDIO in the ADVANCED OPTIONS menu to SAP (the SAP indicator lights up). For details, see page 89.

### To select the bilingual sound while recording

Press AUDIO MONITOR to select the sound you want.

### Selecting the sound during playback

Press AUDIO MONITOR to select the sound you want.

To listen to	On-screen display	Display window
Stereo/main (left and right channels)	STEREO	STEREO
Left channel only	LEFT CH	STEREO
Right channel only	RIGHT CH	STEREO
Monaural (SAP)	No indicator	No indicator

## How sound is recorded on a video tape

The unit's VCR records sound onto two separate tracks. Hi-fi audio is recorded onto the main track along with the picture. Monaural sound is recorded onto the normal audio track along the edge of the tape.

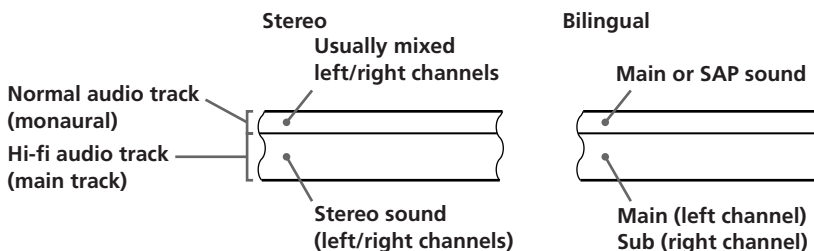

## Searching using the index function

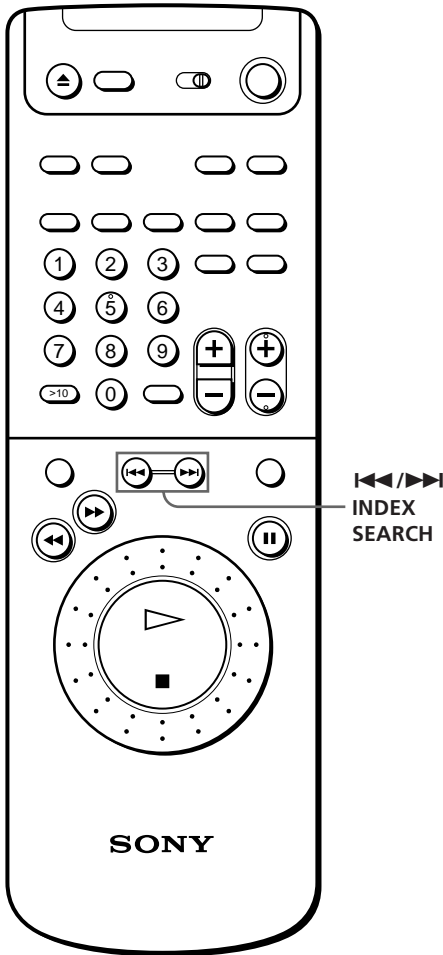

The unit's VCR marks the tape with an index signal at the point where each recording begins. Use these signals as references to find a specific recording. The unit's VCR can search up to 99 index signals ahead of or behind the current position.

- 1 Insert an indexed tape into the unit.
- 2 Press **◀◀ / ▶▶** INDEX SEARCH repeatedly to specify how many index signals ahead or behind you want to search:
  - To search ahead, press **▶▶** INDEX SEARCH.
  - To search behind, press **◀◀** INDEX SEARCH.

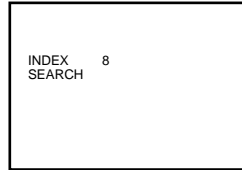

The unit's VCR starts searching and the index number on the TV screen counts down to zero. Playback starts automatically from that point.

### To stop searching

Press **■** STOP.

### Note

- No index signal will be added when recording starts from recording pause. However, an index signal will be marked if you change the channel during recording pause.

# Adjusting the picture

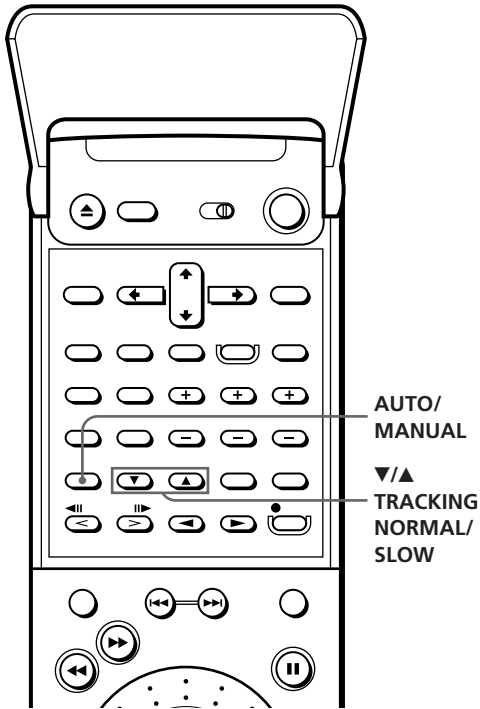

## Adjusting the tracking

Although the unit's VCR automatically adjusts the tracking when playing a tape (the AUTO TRACKING indicator flashes in the display window, then lights steadily), distortion may occur if the tape was poorly recorded. If picture distortion occurs, manually adjust the tracking.

Press ▼/▲ TRACKING NORMAL/SLOW to display the tracking meter. The distortion should disappear as you press one of the two buttons. If you cannot get a clear picture with manual adjustment, press TRACKING AUTO/MANUAL to return to automatic adjustment.

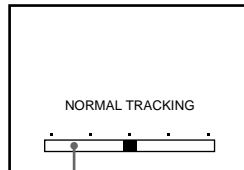

Tracking meter

## About Adaptive Picture Control (APC)

Adaptive Picture Control (APC) automatically improves recording and playback quality by adjusting the unit's VCR to the condition of the video heads and tape. To maintain better picture quality, we recommend that you set APC to ON in the ADVANCED OPTIONS menu (with the APC indicator in the display window lit). See "changing menu options."

ADVANCED OPTIONS		page2
INDICATION	ON	OFF
TAPE SELECT	-120-	-160
AUTO TAPE SPEED	ON	OFF
APC	ON	OFF
SHARPNESS	L	-H
SELECT :	↑ ↓	
SET :	← →	
QUIT :	[MENU]	

### APC playback

The APC function automatically works on all types of tapes, including rental tapes and tapes that were not recorded with APC.

### APC recording

Whenever you insert a tape and first start recording, the unit's VCR adjusts to the tape using the APC function (the APC indicator flashes rapidly). This adjustment remains in effect until the tape is ejected.

### To deactivate the APC

Press MENU and select SET UP MENU, then set APC to OFF. The APC indicator in the display window goes off.

### Notes

- Auto tracking adjustment cannot be used on tapes recorded in the LP mode on other VCRs.
- The APC function does not work if the tape speed is automatically changed from the SP to EP mode during a timer recording, unless the tape has been recorded in the EP mode with the APC function.
- There is a delay of a few seconds before the unit's VCR actually starts recording while the unit's VCR analyses the tape. To avoid the delay, first set the unit's VCR to recording pause (the APC indicator flashes slowly) and press ● REC to have the unit's VCR analyse the tape (the APC indicator flashes rapidly). After the APC indicator stops flashing, press ■ PAUSE to start recording immediately. If you want to start recording quickly without using the APC function, first set the unit's VCR to recording pause (the APC indicator flashes slowly) and press ■ PAUSE to start recording.



# Changing menu options

- 1 Press MENU. Then select VHS MENU and press EXECUTE.
- 2 Press CURSOR  $\uparrow/\downarrow$  to select ADVANCED OPTIONS and press EXECUTE.
- 3 Press CURSOR  $\uparrow/\downarrow$  to select the option to change, then press CURSOR  $\leftarrow/\rightarrow$  to change the setting.

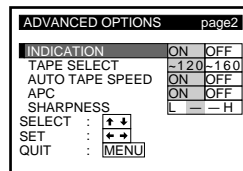
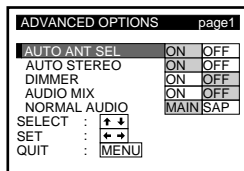

- 4 Press EXECUTE to return to the original screen.

## Menu choices

Initial settings are indicated in bold print.

Menu option	Set this option to
AUTO ANT SEL	<b>ON</b> if your TV is connected only to VHF/UHF OUT on the VCR. To play a tape, set the TV to the VCR channel (channel 3 or 4). <b>OFF</b> if your TV is connected to both VHF/UHF OUT and VIDEO OUT on the VCR. To play a tape, set the TV to the VCR input.
AUTO STEREO	<b>ON</b> to receive stereo programs, <b>OFF</b> to reduce noise. The sound changes to monaural.
DIMMER	ON to make the display window dim, <b>OFF</b> to make it brighter.
AUDIO MIX	ON to listen to the hi-fi and normal audio tracks at the same time. The AUDIO MONITOR button will not function. <b>OFF</b> to listen to the hi-fi and normal audio tracks separately. Select the sound using the AUDIO MONITOR button. For details, see page 86.
NORMAL AUDIO	<b>MAIN</b> to record the main sound on both hi-fi and normal audio tracks. SAP to record the SAP (Second Audio Program) sound on the normal audio track. The main sound is recorded on the hi-fi audio track.
INDICATION	<b>ON</b> to display the operational function and selected sound field for a few seconds in the display window. <b>OFF</b> to display only the indication selected with the STATUS button on the unit. For details, see page 48.
TAPE SELECT	"~120" or "~160" to select the tape length and display the remaining time correctly.
AUTO TAPE SPEED	<b>ON</b> to change the timer recording tape speed automatically to the EP mode when the remaining tape becomes shorter than the recording time, <b>OFF</b> to keep the tape speed.
APC	<b>ON</b> to switch on the APC (Adaptive Picture Control) function and improve the picture quality, <b>OFF</b> to switch off APC. For details, see page 88.
SHARPNESS	L (Low) through H (High) to adjust the sharpness of the picture. L to turn off the sharpness control.

## Editing

# Recording from another VCR or LD player

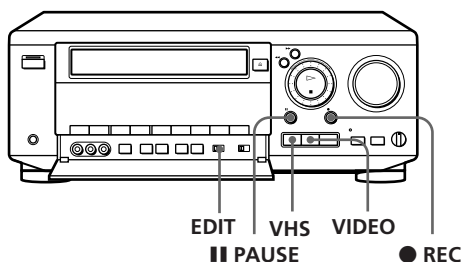

### Tips

- To cut out unwanted scenes while editing, press **II PAUSE** on the unit when an unwanted scene begins. When it ends, press **II PAUSE** again to resume recording (Assemble Editing).
- You can record audio sound from the desired input source on the video tape by pressing **AUDIO** repeatedly in step 4.

### Note

- If you follow this procedure to start recording, the unit's VCR won't record with the APC function. To record a tape with the APC function, press **● REC** again during recording pause in step 2 so the unit's VCR analyses the tape. Then when you start recording in step 6, press **II PAUSE** after the APC indicator stops flashing. If you press **II PAUSE** before the APC indicator stops flashing, the APC function is cancelled.

### Before you start editing

- Connect another VCR or LD player to the unit referring to the connections on pages 8 and 9.
- Press **VHS TUNER**.
  - If the TV doesn't turn on, turn it on manually.
  - If connected with only the antenna cable, set the TV to the video channel.
- Press **TAPE SPEED** to select the tape speed, SP or EP.
- On this unit, set the **EDIT** switch to **ON**. If the other VCR has a similar switch, set it to **ON** as well.
- Do not use the remote commander in the following procedure.

---

**1** Insert a tape with its safety tab in place into the unit (recording VCR).

Search for the point to start recording and press **II PAUSE**.

---

**2** Press **● REC** on the unit to set it to recording pause.

---

**3**

- Insert a source tape with its safety tab removed into the other (playback) VCR when recording from another VCR.
- Insert an LD into the LD player, when recording from an LD player.

---

**4** Press **VIDEO** or **VHS** repeatedly to select the input (playback) source (**VIDEO1**, **VIDEO2**, or **LINE**).

---

**5** Search for the point to start playback and set it to playback pause.

---

**6** To start editing, press **II PAUSE** on this unit and release the pause mode on the other equipment at the same time.

---

### To stop editing

Press the **■ STOP** buttons on both units.

## Additional Information

# Customizing the remote commander function buttons

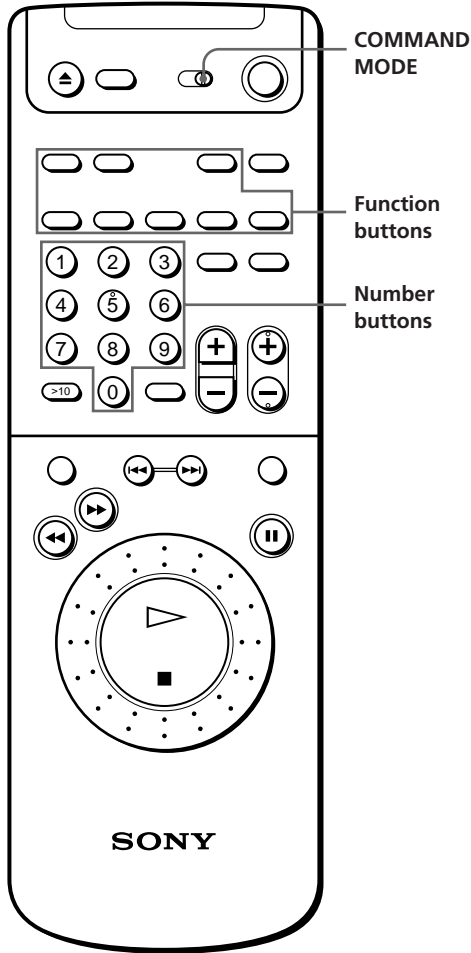

### Notes

- You cannot customize the VHS TUNER, VHS LINE, and TUNER function buttons.
- The COMMAND MODE selectors on both the remote commander and unit (the actual selector's name on the unit is VTR COMMAND MODE) are factory set to VTR3.

The function buttons on the remote commander have two roles. One is to select the input sources (see "Selecting the equipment" on page 59) and the other is to switch the remote commander to operate the selected piece of equipment. The function buttons are factory set for the unit's VCR, a radio tuner, CD player, cassette deck (deck B for double-cassette decks), and TV connected to the source inputs. If you want to control other piece of equipment or restore the factory settings, you need to customize the function buttons. For detailed customizing explanations, see the sections for controlling each piece of equipment (see pages 62 through 74). This section shows you the factory settings of, and the way to customize, the remote commander function buttons.

### Factory set functions

Press	Then, the remote commander operates
VHS TUNER	The unit's VCR (The COMMAND MODE selector determines the controllable VCR.)
VHS LINE	Same as above
VIDEO 1	Same as above
VIDEO 2	Same as above
TUNER	Same as above
CD	A CD player
TAPE/MD	A single cassette deck or deck B of a double-cassette deck
TV	A TV

### To customize the function buttons

To control	While pressing one of the function buttons, press
A CD player	1
A DAT deck	2
An MD deck	3
A single cassette deck or Deck B of a double-cassette deck	4
A single cassette deck or Deck A of a double-cassette deck	5
An LD player	6
A VCR if its COMMAND MODE position/format is	
VTR1/Betamax	7
VTR2/8mm	8
VTR3/VHS	9
A TV	0

### To restore the factory settings for all the function buttons

Remove the batteries from the remote commander, and insert the batteries again.

### To restore the factory settings for VIDEO1 or VIDEO2

See "To relate VIDEO1 or VIDEO2 with COMMAND MODE again" on page 63.

## General setup information

### Setting the RF unit

When connecting this unit to the TV using only the antenna cable, you must set the RF UNIT switch on the rear of the unit so that the TV can receive the correct signal from the this unit.

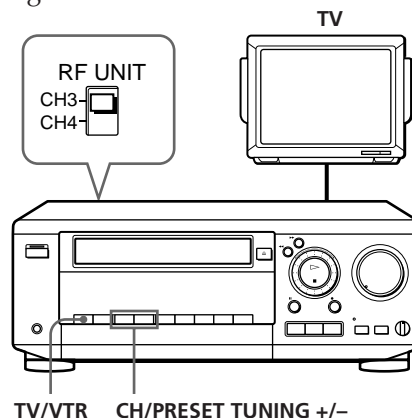

- 1 Set the RF UNIT switch to CH3 or CH4, whichever channel is not used in your area. If both are used, set the switch to either channel.
- 2 Press POWER to turn on this unit.
- 3 Press TV/VTR to turn on the VTR indicator in the unit's display window.
- 4 Press CH/PRESET +/- to display a channel number in the display window. Select an active channel number in your area.
- 5 Turn on your TV and set it to the channel you selected in step 1 (channel 3 or 4).

The selected TV channel broadcast appears on the TV screen. If the channels change when you press CH/PRESET +/- on this unit, you have made the correct setting.

Whenever you use this unit, set the TV to the channel selected in step 1.

### Attaching the external antenna connector

When using a 300-ohm twin lead cable for VHF/UHF antenna, use the EAC-32 antenna connector (not supplied) to connect the antenna to the VCR.

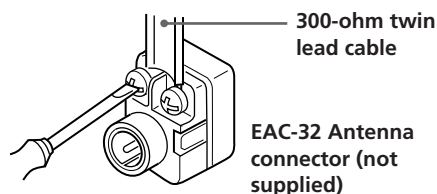

- 1 Loosen the screws on the antenna connector.
- 2 Wind the twin leads around the screws on the antenna connector.
- 3 Retighten the screws.

## Attaching a UHF/VHF band mixer

When using both 75-ohm coaxial cable and 300-ohm twin lead cable for VHF/UHF antenna, use the EAC-66 UHF/VHF band separator/mixer (not supplied) to connect the antenna to the VCR.

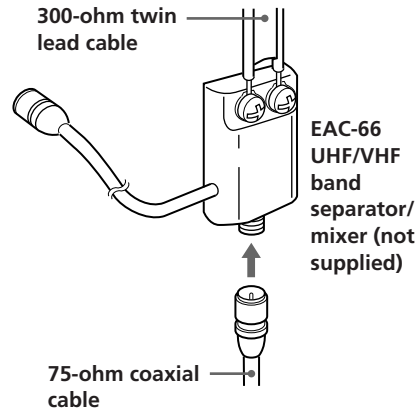

- 1 Loosen the screws on the mixer.
- 2 Wind the twin leads around the screws on the mixer.
- 3 Retighten the screws.
- 4 Connect the 75-ohm coaxial cable to the mixer.

# Troubleshooting

If you have any questions or problems not covered below, please consult your nearest Sony service facility.

	Symptom	Remedy
<b>Unit's power</b>	The POWER switch doesn't function.	<ul style="list-style-type: none"> <li>Connect the AC power cord securely.</li> </ul>
	The power is turned on but the unit doesn't operate.	<ul style="list-style-type: none"> <li>Moisture condensation has occurred. Turn the power off, unplug the AC power cord and leave the unit to dry for over one hour.</li> </ul>
<b>Clock</b>	The clock has stopped and "--:--" lights in the display window.	<ul style="list-style-type: none"> <li>The clock stops if the unit is disconnected from the wall outlet for more than one hour. Reset the clock (and timer).</li> </ul>
<b>Playback</b>	The playback picture does not appear on the TV screen.	<ul style="list-style-type: none"> <li>Make sure the TV is set to the channel for the VCR. If you are using a monitor, set it to video input.</li> </ul>
	The picture is not clear.	<ul style="list-style-type: none"> <li>Adjust the tracking with the TRACKING NORMAL/SLOW buttons.</li> <li>The video heads are dirty (see below). Clean the video heads using the Sony V-25CL video head cleaning cassette. If this cleaning cassette is not available in your area, have the heads cleaned at your nearest Sony service facility (a standard service charge will be required). Do not use a commercially available wet-type cleaning cassette, as it may damage the video heads.</li> <li>The video heads may have to be replaced. Consult your local Sony service facility for more information.</li> <li>Place the TV away from the audio components.</li> </ul>
	The picture rolls vertically during picture search.	<ul style="list-style-type: none"> <li>Adjust the vertical hold control on the TV or monitor.</li> </ul>
	The picture has no sound.	<ul style="list-style-type: none"> <li>The tape is defective. Use a new tape.</li> </ul>
	Both main and SAP sounds are heard.	<ul style="list-style-type: none"> <li>When you play a bilingual tape, make sure the AUDIO MIX option in the ADVANCED OPTIONS is set to OFF.</li> </ul>

## Symptoms caused by contaminated video heads

- Normal picture
- Rough picture
- Unclear picture
- No picture (or black & white screen appears)

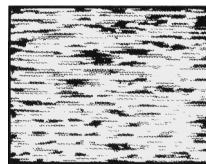
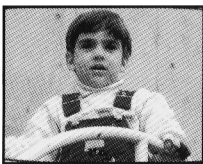

initial → terminal

	<b>Symptom</b>	<b>Remedy</b>
<b>Recording and TV reception</b>	No TV program appears on the TV screen.	<ul style="list-style-type: none"> <li>• Make sure the TV is set to the video channel. If you are using a monitor, set it to video input.</li> </ul>
	TV reception is poor.	<ul style="list-style-type: none"> <li>• Adjust the TV antenna.</li> <li>• Place the TV away from the audio components.</li> </ul>
	The tape starts playing as soon as it is inserted.	<ul style="list-style-type: none"> <li>• The safety tab has been removed. To record on this tape, cover the tab hole.</li> </ul>
	The tape is ejected when you press ● REC.	<ul style="list-style-type: none"> <li>• Check that the safety tab has not been removed.</li> </ul>
	Nothing happens when you press ● REC.	<ul style="list-style-type: none"> <li>• Make sure the tape is not at its end.</li> <li>• If you want to record from other equipment, select the correct source with the function buttons <u>on the unit</u>. If you select the input source with the remote commander function buttons, the remote commander may be switched to control other equipment. Make sure the remote commander is set for the unit's VCR control if you use ● REC on the remote commander.</li> </ul> <p>If you want to record TV programs, press VHS TUNER on the remote commander, then select a channel.</p>
<b>Timer recording</b>	The timer does not operate.	<ul style="list-style-type: none"> <li>• Check that the clock is set.</li> <li>• Make sure a tape has been inserted.</li> <li>• Check that the safety tab has not been removed.</li> <li>• Make sure the tape is not at its end.</li> <li>• Make sure a program has been set for timer recording.</li> <li>• Make sure you press TIMER REC ON/OFF to set the unit to timer recording standby.</li> <li>• Make sure the current time has not already passed your timer settings.</li> <li>• Check that the cable box is turned on.</li> <li>• Check that the DSS receiver is turned on.</li> <li>• The clock stops if the unit is disconnected from the wall outlet for more than one hour. Reset the clock and timer.</li> </ul>
<b>Other VCR problems</b>	A tape cannot be inserted.	<ul style="list-style-type: none"> <li>• Check that a tape isn't already in the tape compartment.</li> </ul>
	The tracking indicator does not appear on the screen.	<ul style="list-style-type: none"> <li>• The recording condition of the tape is very poor and tracking cannot be adjusted.</li> </ul>
	The unit needs to be cleaned.	<ul style="list-style-type: none"> <li>• Clean the cabinet, panel and controls with a soft, dry cloth, or a soft cloth slightly moistened with a mild detergent solution. Do not use any type of solvent, such as alcohol or benzine.</li> </ul>

**continued**

## Troubleshooting (continued)

	Symptom	Remedy
<b>Amplifier</b>	There's no sound or only a very low-level sound is heard.	<ul style="list-style-type: none"><li>• Check that the speakers and components are connected securely.</li><li>• Press MUTING if the  (muting) indicator is displayed on the TV screen or the MASTER VOLUME indicator on the unit flashes.</li><li>• The headphones are connected to PHONES. Disconnect the headphones.</li><li>• The protective device on the unit has been activated because of a short circuit. ("PROTECT" appears in the display window.) Turn off the unit, then eliminate the cause of the short-circuit and turn on the unit again.</li></ul>
	The left and right sounds are unbalanced or reversed.	<ul style="list-style-type: none"><li>• Check that the speakers and components are connected correctly and securely.</li><li>• Adjust BALANCE L/R on the unit.</li></ul>
	Severe hum or noise is heard.	<ul style="list-style-type: none"><li>• Check that the speakers and components are connected correctly and securely.</li><li>• Check that the connecting cords and cables are away from a transformer or motor, and at least 3 meters away from a TV set or fluorescent light.</li><li>• Place your TV away from the audio components.</li><li>• The plugs and jacks are dirty. Wipe them with a cloth slightly moistened with alcohol.</li></ul>
	No sound or a very low-level sound is heard from the rear speakers or center speaker.	<ul style="list-style-type: none"><li>• Select the appropriate center mode.</li><li>• Adjust the speaker volume appropriately.</li><li>• Make sure you turn on the sound field surround mode function.</li><li>• Make sure you select a suitable sound field for the playback source.</li></ul>
	The surround effect cannot be heard.	<ul style="list-style-type: none"><li>• Make sure you turn on the sound field function.</li><li>• Make sure you select a suitable sound field for the playback source.</li></ul>
<b>Remote commander</b>	The remote commander does not function.	<ul style="list-style-type: none"><li>• Make sure you are pointing the remote commander at the remote sensor on the unit or equipment you want to control.</li><li>• Replace all the batteries in the remote commander with new ones if they are weak.</li><li>• Make sure you press the correct remote commander function button to set the remote commander for the equipment you want to control.</li><li>• Remove obstacles in the path of the remote commander and the receiver.</li></ul>



# Specifications

## System

### Channel coverage

VHF 2 to 13  
UHF 14 to 69  
CATV A-8 to A-1, A to W, W+1 to W+84

### Antenna

75-ohm antenna terminal for VHF/  
UHF

## VCR Inputs and outputs

### VIDEO 1 IN

### VIDEO 2 INPUT

### LINE IN

VIDEO IN, phono jack (1)  
Input signal: 1 Vp-p, 75 ohms,  
unbalanced, sync negative  
AUDIO IN, phono jacks (2)  
Input level: 327 mVrms  
Input impedance: more than 47  
kilohms

### MONITOR VIDEO OUT

Phono jack (1)  
Output signal: 1 Vp-p, 75 ohm  
(unbalanced), sync negative

### TV IN

VIDEO IN, phono jack (1)  
Input signal: 1 Vp-p, 75 ohms,  
unbalanced, sync negative  
AUDIO IN, phono jack (2)  
Input level: 327 mVrms  
Input impedance: more than 47  
kilohms

## Amplifier

### USA model:

### AUDIO POWER SPECIFICATIONS

### POWER OUTPUT AND TOTAL HARMONIC DISTORTION

**With 8-ohm load, both channels driven, from 20-20,000 Hz, rated 80 watts per channel minimum RMS power, with no more than 0.09% total harmonic distortion from 250 milliwatts to rated output.**

### Power output

#### Canadian model:

Stereo mode (8 ohms at 20 Hz - 20 kHz less than 0.09% total harmonic distortion)  
70 W + 70 W

### Surround mode

#### USA model:

(8 ohms at 1 kHz, THD 0.8%)  
Front 80 W/ch  
Center 80 W  
(only in the PRO LOGIC and THEATER mode)  
Rear 80 W  
Dynamic power output  
8 ohms: 125 W + 125 W  
4 ohms: 165 W + 165 W

### Canadian model:

(8 ohms at 1 kHz, THD 0.8%)  
Front 70 W/ch  
Center 70 W  
(only in the PRO LOGIC and THEATER mode)  
Rear 70 W  
Dynamic power output  
8 ohms: 95 W + 95 W  
4 ohms: 130 W + 130 W

### Frequency response

CD, TAPE/MD, VIDEO 1, VIDEO 2, TV, and LINE : 10 Hz - 50 kHz  $\pm$  1 dB

### Inputs

#### CD

Sensitivity 220 mV  
Impedance 50 kilohms  
S/N 82 dB,  
(Weighting 82 dB ('78 IHF)  
network, input (A, 0.5 V)  
level)

#### TAPE/MD, VIDEO1, VIDEO2, TV, and LINE

Sensitivity 180 mV  
Impedance 50 kilohms  
S/N 82 dB,  
(Weighting 82 dB ('78 IHF)  
network, input (A, 0.5 V)  
level)

### Outputs

#### TAPE/MD REC OUT

Voltage 180 mV,  
Impedance 10 kilohms

#### MIX AUDIO OUT

Voltage : 2 V  
Impedance : 10 kilohms

#### PHONES

Accepts low and high impedance headphones

### Muting

-20 dB

### BASS BOOST

+10 dB at 70 Hz

### TONE

$\pm$ 8 dB at 100 Hz and 10 kHz

### FM tuner section

Tuning range  
87.5 - 108.0 MHz  
Antenna terminal  
75 ohms, unbalanced

### AM tuner section

Tuning range  
With 10 kHz interval\*\*:  
530 - 1710 kHz  
With 9 kHz interval:  
531 - 1710 kHz  
Antenna Loop antenna

\*\*You can change the AM tuning interval to 9 kHz. After turning in any AM station, turn off the power, hold down the FM/AM button and press the POWER switch. To reset the interval to 10 kHz, repeat the procedure.

## General

### Power requirements

120 V AC, 60 Hz

### Power consumption

190 W

### AC outlet

Switched 120 W / 1A MAX

### Operating temperature

5°C to 40°C

### Storage temperature

-20°C to 60°C

### Dimensions

Approx. 430  $\times$  157  $\times$  430 mm  
(17  $\times$  6<sup>1</sup>/<sub>4</sub>  $\times$  17 inches) (w/h/d)  
including projecting parts and controls

### Mass

USA model:  
Approx. 13.3 kg (29 lb 6 oz)  
Canadian model:  
Approx. 13.0 kg (28 lb 11 oz)

### Supplied accessories

Remote commander (1)  
Size AA (R6) batteries (2)  
75-ohm coaxial cable with F-type connectors (1)  
Video cable (1 phono to 1 phono) (1)  
AM loop antenna (1)  
FM wire antenna (1)

Design and specifications are subject to change without notice.

# Index to parts and controls

## Front panel

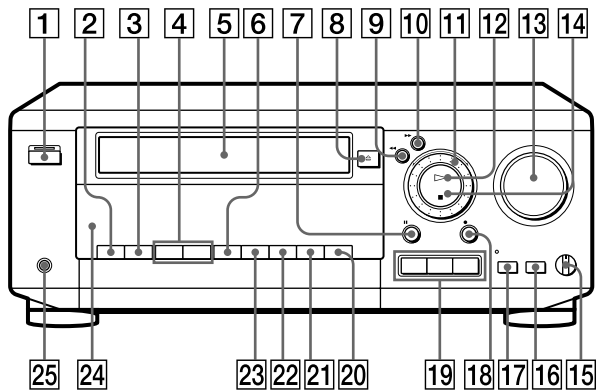

- 1 POWER switch/indicator
- 2 TV/VTR button (39, 92)
- 3 TAPE SPEED button (50)
- 4 CH/PRESET TUNING +/- buttons (41)
- 5 Tape compartment (47)
- 6 FM/AM button (45)
- 7 ■ PAUSE button (90)
- 8 ▲ EJECT button (47)
- 9 ◀ REW button (47)
- 10 ▶▶ FF button (47)
- 11 Shuttle ring (45, 84)
- 12 ▷ PLAY button (47)
- 13 MASTER VOLUME control/indicator (47, 48)
- 14 ■ STOP button (90)
- 15 BALANCE L/R control (31, 82)
- 16 MUTING button (48)
- 17 SURROUND button/indicator (75, 78)
- 18 ● REC button (90)
- 19 FUNCTION buttons (45, 60, 67, 70, 72, 90)
- 20 STATUS button (48)
- 21 FM MODE button (90)
- 22 TUNING MODE button (45)
- 23 SHIFT button (46)
- 24 Remote sensor (5)
- 25 PHONES jack (7)

## Front panel, with cover opened

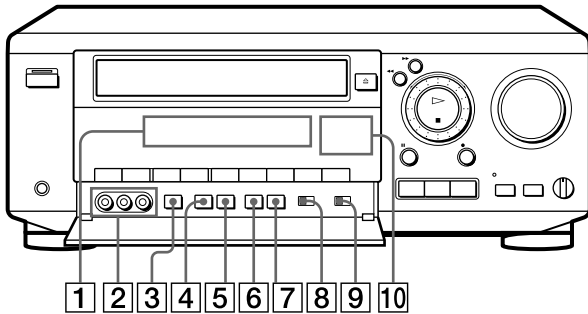

- 1 Display window (48)
- 2 VIDEO 2 INPUT VIDEO/AUDIO L/R jacks (9)
- 3 EASY SET UP button (14, 17, 20, 23, 26, 28)
- 4 TIMER REC (ON/OFF) button (52)
- 5 QUICK TIMER button (85)
- 6 COUNTER RESET button (48)
- 7 MEMORY button (46)
- 8 EDIT ON/OFF switch (90)
- 9 VTR COMMAND MODE OFF/1/2/3 selector (62)
- 10 Tape operation indicators

## Display window

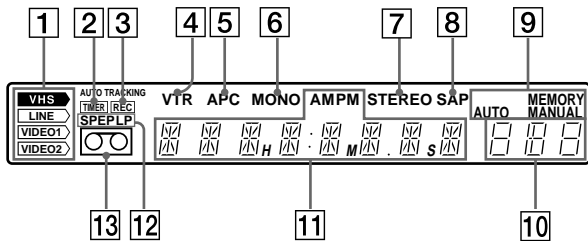

- 1 Video input indicators (60)
- 2 TIMER indicator (52, 55, 85)
- 3 REC indicator (85)
- 4 VTR indicator (92)
- 5 APC indicator (88, 89)
- 6 MONO indicator (45)
- 7 STEREO indicator (45)
- 8 SAP indicator (86)
- 9 AUTO/MANUAL/MEMORY indicators (45, 46)
- 10 Line/channel indicator (50)
- 11 Time counter/clock/operating function/sound field indications (48)
- 12 Tape speed indicators (50)
- 13  (tape) indicator

**continued**

## Index to parts and controls

(continued)

### Rear panel

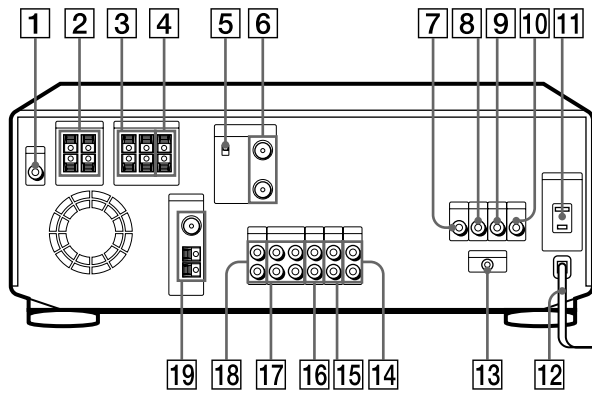

- 1 MIX OUT jack (7)
- 2 FRONT SPEAKERS L/R connectors (6)
- 3 SURROUND SPEAKERS REAR L/R connectors (7)
- 4 SURROUND SPEAKERS CENTER connectors (6)
- 5 RF UNIT switch (92)
- 6 VHF/UHF IN/OUT connectors (13, 16, 19, 22, 25, 27)
- 7 MONITOR VIDEO OUT jack (8)
- 8 TV IN VIDEO jack (8)
- 9 VIDEO 1 IN VIDEO jack (8)
- 10 LINE IN VIDEO jack (8)
- 11 AC OUTLET (9)
- 12 AC power cord (9)
- 13 CONTROL S OUT jack (13, 25)
- 14 LINE IN AUDIO L/R jacks (8)
- 15 VIDEO 1 IN AUDIO L/R jacks (8)
- 16 TV IN AUDIO L/R jacks (8)
- 17 TAPE/MD REC OUT/IN AUDIO L/R jacks (8)
- 18 CD IN AUDIO L/R jacks (8)
- 19 ANTENNA terminal (8)

## Remote commander

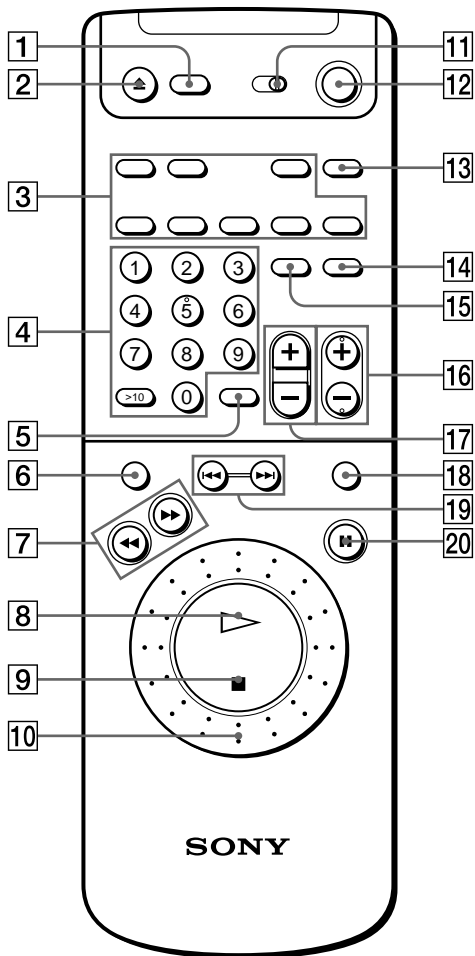

- 1 TV CONTROL ON button (65)
- 2 ▲ EJECT button (47)
- 3 SYSTEM CONTROL/FUNCTION buttons (59~74, 91)
- 4 Number/>10 (66, 71, 74)/SHIFT (58) /SET (52) buttons
- 5 ENTER/RMS/START button (50)
- 6 SMART CUE/D.SKIP button (66, 84)
- 7 ◀◀ REW/▶▶ FF buttons (47, 66, 67, 69, 71, 73, 84)
- 8 ▷ PLAY button (47, 66, 69, 71, 63)
- 9 ■ STOP button (47, 66, 67, 69, 71, 73)
- 10 Shuttle ring (45, 84)
- 11 COMMAND MODE VTR1/2/3 selector (62, 91)
- 12 SYSTEM OFF button (61)
- 13 VISUAL POWER button (62, 65, 74)
- 14 TV/VIDEO button (65)
- 15 VCR Plus+ button (51)
- 16 CH/PRESET +/- buttons (41)
- 17 MASTER VOL +/- buttons (47, 61)
- 18 MUTING button (48, 61)
- 19 ◀◀ /▶▶ INDEX SEARCH (76)/AMS (66, 69, 71, 73) buttons
- 20 || PAUSE button (47, 66, 67, 70, 71, 73)

continued

## Index to parts and controls (continued)

### Remote commander, with top cover opened

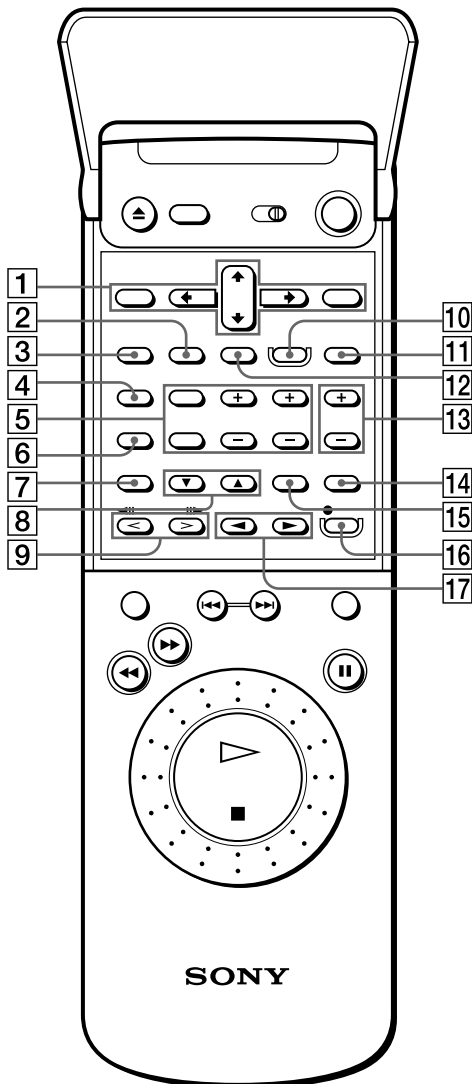

- 1 MENU/CURSOR  $\uparrow/\downarrow/\leftarrow/\rightarrow$ /EXECUTE buttons (30, 33)
- 2 DISPLAY button (48-50)
- 3 AUDIO MONITOR button (86, 89)
- 4 AUTO button (84)
- 5 TV POWER/TV/VIDEO/TV CH+/-/TV VOL +/- buttons (65)
- 6 COUNTER RESET (48) button
- 7 TRACKING AUTO/MANUAL (88)/ANALOG/ $\square$  (CX) (74) button
- 8  $\nabla/\blacktriangle$  TRACKING NORMAL/SLOW (88)/ $\nabla/\blacktriangle$  STILL ADJUST (84) buttons
- 9  $\blacktriangleleft/\triangleright$  FRAME buttons (74, 84)
- 10 TIMER REC ON/OFF button (52, 55)
- 11 TIMER CLEAR button (52, 56)
- 12 TV WIDE button (64)
- 13 CH +/- (64) buttons
- 14 TAPE SPEED (SP/EP) button (50)
- 15 STATUS button (48)
- 16  $\bullet$  REC button (50, 68, 70, 72)
- 17  $\blacktriangleleft/\triangleright$  DIRECTION (67, 72, 74)/ $\triangleright$  SIDE A/ $\blacktriangleleft$  SIDE B (73) buttons

---

# Index

## A, B

- Accessories supplied 4
- Adjusting
  - delay time 77
  - picture 84, 88
  - speaker volume 31, 47, 82
  - tone 79
  - tracking 88
- AFT (Auto Fine Tuning) 42
- APC (Adaptive Picture Control) 88
- Audio component hookups 8, 9
- Audio track 86
- Audio/video equipment control 59
- Automatic tuning 39

## C

- Cable Box Control
  - Cable box code number chart 36
  - setting 35
- Cable hookup 13
- Cable Mouse 13, 38
- Cancelling timer settings 56
- Center mode 32
  - NORMAL mode 32
  - PHANTOM mode 32
  - 3CH LOGIC mode 32
  - WIDE mode 32
- Changing timer settings 56
- Cleaning the video heads 94
- Clock setting 33
- Connecting
  - Cable TV 12
  - external antenna connector 92
  - UHF/VHF band mixer 93
  - to audio/video equipment 8, 9
  - to speaker systems 6
- Counter 48

## D

- Delay time 77
- Display 48
- Dolby Pro Logic Surround 75, 77
- Dolby Surround sound 77
  - center mode 32
- DSS (Digital Satellite System) 35

## E, F, G

- EASY SET UP 14, 17, 20, 23, 26, 28
- Editing 90
- EP mode 51

## H

- Hi-fi audio track 86
- Hookups. *See* Connecting

## I, J, K, L

- Index
  - searching 87

## M

- Monitoring
  - during playback 86
  - during recording 86

## N, O

- Normal audio track 86
- NORMAL mode 32

## P

- PHANTOM mode 32
- Picture adjustment. *See* Adjusting
- Playback 47
  - at various speeds 47, 84
  - frame-by-frame 84
  - skip 84
  - slow motion 84
- Presetting
  - channels 39
  - radio stations 45
- Program source selection 59

## Q

- Quick timer 85

## R

- Recording 50
  - bilingual programs 86
  - SAP broadcasts 86
  - stereo programs 86
  - using VCR Plus+ 51
  - while watching another program 50
- Receiving broadcasts
  - directly 58
  - using preset stations 45
- Remote commander 5
  - Audio/video control 59

## S

- Safety tab 50
- SAP (Second Audio Program) 86
- Scanning
  - preset stations 45
  - radio stations 45
- Searching
  - at various speeds 47, 84
  - using the index function 87

SP mode 50

## Speakers

- connection 6
  - impedance 97
  - placement 7
  - selecting speaker system 32
- Storing radio stations. *See* Presetting
- Surround sound 75, 76

## T, U

- Test tone 31, 82
- 3CH LOGIC mode 32
- Timer recording 51, 54, 85
  - cancelling timer settings 56
  - changing timer settings 56
  - checking timer settings 56
  - daily/weekly recording 55
  - overlapping timer recordings 57
  - using VCR Plus+ 51
- Tracking adjustment. *See* Adjusting
- TV antenna or cable hookups 11

## V

- VCR Plus+
  - channel setup 43
  - recording 51

## W, X, Y

- WIDE mode 32

# Quick reference to using the VCR

## Hookup 1

### To play a tape

- 1 Set the TV to channel 3 or 4 (or to video input, if you made V connection.)
- 2 Insert a tape and press PLAY.

### To record a program

- 1 Turn on the cable box.
- 2 Press VCR Plus+ on the remote commander.
- 3 Enter the program's PlusCode number.
- 4 Select ONCE, DAILY, or WEEKLY in the VCR Plus menu.
- 5 Insert a tape.
- 6 Press POWER to turn off the VCR.
- 7 Leave the cable box on.

### To watch TV

- 1 Turn off your VCR, or press the VCR's TV/VTR button until the VTR indicator in the display window goes off.
- 2 Turn on your cable box.
- 3 Set the TV to the cable box output channel (usually 2, 3, or 4).
- 4 Set the cable box to the channel you want to watch.

## Hookup 2

### To play a tape

- 1 If you made V connection, set the TV to video input.  
If you didn't use V hookup:
  - Turn on the cable box.
  - Set the cable box to channel 3 or 4.
  - Set the TV to the output channel of the cable box (usually 2, 3 or 4).
- 2 Insert a tape and press ▷ PLAY.

## To record a program

- 1 Press VCR Plus+ on the remote commander.
- 2 Enter the program's PlusCode number.
- 3 Select ONCE, DAILY, or WEEKLY in the VCR Plus menu.
- 4 Insert a tape.
- 5 Press POWER to turn off the VCR.

## To watch TV

- 1 Turn off your VCR, or press the VCR's TV/VTR button until the VTR indicator in the display window goes off.
- 2 Select the channel with your cable box (if you have one) or with your TV.

## Hookup 3

### To play a tape

- 1 Set the TV to channel 3 or 4 (or to video input, if you made V connection.)
- 2 Insert a tape and press ▷ PLAY. If there's no picture on your TV, press the VCR's TV/VTR button until the VTR indicator comes on in the display window.

## To record a program

- 1 Press VCR Plus+ on the remote commander.
- 2 Enter the program's PlusCode number.
- 3 Select ONCE, DAILY, or WEEKLY in the VCR Plus menu.
- 4 Insert a tape.
- 5 Press POWER to turn off the VCR.

## To watch TV

- 1 Turn off the VCR, or press the VCR's TV/VTR button until the VTR indicator in the display window goes off.
- 2 Set the TV to the channel you want to watch.

## Hookup 4

### To play a tape

- 1 Set the TV to channel 3 or 4 (or to video input, if you made V connection.)
- 2 Insert a tape and press ▷ PLAY.

### To record a program

- 1 Turn on the cable box.
- 2 Set the cable box to the channel you want to record.
- 3 Press VCR Plus+ on the remote commander.
- 4 Enter the program's PlusCode number.
- 5 Select ONCE, DAILY, or WEEKLY in the VCR Plus menu.
- 6 Insert a tape.
- 7 Press POWER to turn off the VCR.
- 8 Leave the cable box on.

### To watch TV

- 1 Turn off your VCR, or press the VCR's TV/VTR button until the VTR indicator in the display window goes off.
- 2 Turn on your cable box.
- 3 Set the TV to the cable box output channel (usually 2, 3, or 4).
- 4 Set the cable box to the channel you want to watch.

If you have any questions about this product, you may call: **Sony Customer Information Center** 1-800-222-SONY (7669) or write to: **Sony Customer Information Center** Sony Drive, Mail Drop #T1-11, Park Ridge, NJ 07656